



**pcas**

Portable Collision  
Avoidance Systems

# Owner's Manual

**PCAS XRX**

September 2008



# Portable Collision Avoidance System™ (PCAS™)

## Model XRX™ Owner's Manual

Copyright © 2005-2008 Zaon Flight Systems, Inc., Addison, Texas, USA  
Part number 3000-9101 Rev 9/08  
Printed in the USA

### **Versions**

Manual Version 3.0  
Firmware Version 2.0 and prior

No part of the enclosed manual may be reproduced, stored for retrieval, nor transmitted or recorded in any form by any means including, but not limited to, electronic, mechanical, digital or analog, without the prior express written permission of Zaon Flight Systems, Inc. All trademarks contained herein are owned by Zaon Flight Systems, including, but not limited to, XRX™, PCAS™ and Bubble of Awareness™. Every effort has been made to make the enclosed manual as complete and accurate as possible, but no warranty of any kind whatsoever is implied. The manual is for informational use only. Zaon Flight Systems, Inc. assumes no responsibility or liability for any errors or inaccuracies that may appear in the enclosed manual.



# Table of Contents

## 1 Introduction

Thank You .....	1
Terminology .....	1
Cautions & Warnings .....	2
Manual/Unit Differences .....	2

## 3 Setup

Step-by-Step .....	3
XRX At-A-Glance .....	3
Unpacking .....	4
Placement Considerations .....	4
Cable Routing .....	4
Keeping Clear of Obstructions .....	5
Rubber Feet .....	5
Velcro® Mounting Tabs .....	5
Connecting the Power .....	5
Connecting to Permanent/Hardwired Power .....	6
Connecting the Audio .....	6
Standard Headset-Direct™ Configuration .....	6
In-cabin Audio .....	7
Testing the Audio Output .....	7
Headset Adaptors .....	7
Configuring the Audio .....	7
Direct Wiring .....	8
Antenna .....	8
Initial Calibration .....	9
Pressurized Aircraft .....	9
Controls & Functions .....	10
Carry Case .....	10

## 11 Understanding PCAS

What is PCAS? .....	11
What does XRX show? .....	11
The Detection Window .....	11
The Traffic Screen .....	12
Screen A & B Information .....	12
Target Information .....	12
Screen B Only .....	12

Screen A Only .....12

Vertical Trend .....13

Local Information .....14

Ground Mode vs. Flight Mode .....14

Threat Prioritizing .....15

Resolution & Accuracy .....15

Traffic Advisories and Alerts .....16

How does XRX work? .....17

    How is direction obtained? .....17

    The Importance of Relative Information .....17

    Built-in Compass for Relative Bearing .....18

    Built-in Altimeter for Relative Altitude .....18

    How altitude is accurately determined inside a cockpit .....18

What does XRX detect exactly? .....24

Example Flight Scenarios .....26

    Example 1: A Single Aircraft .....27

    Example 2: Prioritizing .....28

    Example 3: Prioritizing Close Altitudes .....29

    Example 4: Same Altitude for Multiple Aircraft .....30

**31 Strengths and Limitations**

Strengths .....31

    Ground RADAR and TCAS Network Coverage .....31

    Zero False Alerts .....32

Limitations .....32

    XRX Cannot Detect All Traffic .....32

    Realistic Detection Window .....32

    Cones of Confusion .....33

    North Turning Compass Error .....34

    Visually Identifying Aircraft .....35

    Recognition & Reaction Time .....35

**36 Buttons and Functions**

Menus .....37

Hierarchy and Selecting .....37

Menu 1: Aircraft Type .....38

Menu 2: Range .....39

Menu 3: Altitude .....40

Menu 4: Third-Party Communications Setup (Com) .....41

Menu 5: Screen Options .....42

Additional Menus: Administrative Mode .....43

Menu Hierarchy .....	44
Page 1: Compass Calibration .....	45
Page 2: General Information .....	46
System Audio Test .....	46
Page 3: Altimeter Calibration .....	47
Saving the Settings .....	47
<b>48 Frequently Asked Questions</b>	
<b>52 Troubleshooting</b>	
Power .....	52
Traffic Detection .....	52
A Note About ATC Services .....	53
<b>56 Appendices</b>	
Appendix A: Specifications .....	56
Accessories .....	57
Appendix B: Configuration Switches .....	58
Appendix C: Customer Service .....	59
Online Support .....	59
Personal Support .....	59
Appendix D: Firmware .....	60
Upgrading the Firmware .....	60
Firmware Change History .....	60
Version 2.0 .....	60
Appendix E: Warranty Information .....	62
Three-Year Limited Warranty .....	62
To Return Your Unit For Repair .....	62
To Return Your Unit For A Refund .....	62
Register Your Unit .....	63
Appendix F: Installation and FAA .....	64
Usage Limitations .....	64
FAA Certification .....	64
Audio Schematic .....	64
Appendix G: Regulatory Information .....	66
FCC Regulations .....	66
Canadian Regulations .....	66
European Economic Community Declaration of Conformity .....	66
<b>68 Index</b>	
Table Index .....	69
My Information .....	70

This page left blank intentionally.

# Introduction

## Thank You

Congratulations on your purchase of the Zoon XRX. This unit incorporates fourth-generation PCAS technology in a compact feature-filled unit. PCAS, or Portable Collision Avoidance System, is the technology developed exclusively by Zoon Flight Systems that makes this unit possible.

XRX offers many other innovative elements, and first-time users may encounter a slight learning curve. Every effort has been afforded to provide a concise manual with clear, comprehensive explanations of all features.

We are pleased to offer you the latest in avionics technology, designed for your personal protection. After reading the manual through, we look forward to hearing from you should you have any questions or concerns.

Sincerely,

Zoon Flight Systems, Inc.  
Avionics Research & Development



***Please read through this manual in its entirety and completely familiarize yourself with XRX features before operating the unit.***

## Terminology

The following terminology is used in this manual, supporting and supplementary documentation, and throughout Zoon documentation and web-based media.

- PCAS** Portable Collision Avoidance System(s). Refers to the general technology developed to make collision avoidance portable. May include one or more specific models (ie: XRX and/or MRX, etc.). This technology was developed exclusively by Zoon Flight Systems.
- XRX** A specific model of PCAS technology with a specific set of abilities.
- TCAS** Traffic alert and Collision Avoidance System(s). Refers to the active traffic system used primarily by airliners. The system is independent of ATC or ground RADAR

## Cautions & Warnings

**As with all collision avoidance devices, XRX may not detect all aircraft within the detection window.**

- > XRX is not recommended as a substitute for proper traffic scanning procedures as listed in the FAA Airman's Information Manual and under the "See and Avoid" concept presented in FAA AC90-48C. This unit is intended as an additional tool in determining potential traffic threats.
- > NEVER operate the unit with a headset, or any other audio components, at high-volume levels. Hearing experts advise against continuous high-volume operation. Should you experience a ringing in your ears, immediately reduce the volume level or discontinue use.
- > Until you are familiar with the operations and limitations of this unit, abrupt changes in the control of the aircraft should be avoided unless positive identification with the traffic is made, or you have been ordered to do so by the Air Traffic Controller. The FAA, their representatives, as well as published airspace regulations, always supersede any indication given by this unit.
- > NEVER connect unit to an AC outlet. This may pose a fire hazard or result in an electric shock. NEVER connect the unit to a power source of more than 40V DC. Such a connection will harm the receiver and poses a fire hazard. NEVER connect a non-fused, external power source to the unit. This may result in damage to the unit and may pose a fire hazard. DO NOT connect the unit to any power source using reverse polarity. Doing so may also damage the unit. Follow the guidelines in this manual explicitly when connecting to an external power source.
- > NEVER expose the unit to rain, snow or any liquid. Avoid placing the receiver in excessively dusty, hot, or cold environments. DO NOT use or place unit in areas with temperatures below -20°C (-4°F) or above +55°C (130°F).
- > AVOID the use of chemical agents such as benzene or alcohol when cleaning, as they damage the unit surfaces.

### Manual/Unit Differences

**Illustrations:** The photos and illustrations in this manual may vary slightly from your unit. These differences are aesthetic only and should not change the functionality of your unit. From time to time, slight modifications are made for any number of reasons, and Zaon reserves the right to make these modifications without prior notification to customers.

**Manual:** The information contained in this manual, including numbers and figures, are subject to change without prior notice.

The latest manual will be available online at [www.zaon.aero](http://www.zaon.aero) for downloading if revisions are issued. Refer to the version numbers inside the front cover of this manual.



# Setup

## Step-by-Step

- 1 > Unpack unit and accessories.....page 4
- 2 > Register your unit.....page 63
- 3 > Determine placement and cable routing.....page 4
- 4 > Set configuration switches, if necessary.....page 7, 9, 58
- 5 > Hookup power and audio (optional).....page 5 - 7
- 6 > Place unit and turn on.....page 4 - 5, 10

## XRX At-A-Glance

- > "3-D" view Quadrant Direction, 45° increments
- > Digital range, scalable from 6NM to 1NM
- > Relative altitude, scalable from ±2500 ft to ±500 ft, with ascending/descending indicator
- > Multiple traffic information
- > Menu-driven interface, with selectable aircraft profiles and advanced calibration options
- > A built-in altimeter, a built-in compass, and a built-in turn/bank sensor, and internal thermometer provide the highest, real-time accuracy available
- > Displays the local squawk code, altitude, bank angle, bearing and temperature
- > Audio voice alerts for threats and advisories are included, with both Headset-Direct™ hookup and in-cabin output, as well as RS-232 out for integration with other systems.

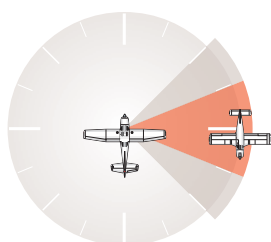

Quadrant Bearing

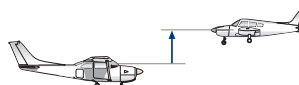

relative altitude + trend

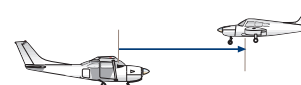

digital range

## Unpacking

Your XRX system contains everything you need for basic operation right out of the box. If any listed items are missing, please contact Zaon directly for replacement (see page xx, "Appendix C: Customer Service").

	Description	Page
A >	PCAS XRX unit	10
B >	Carrying Case	10
C >	Power adapter	5-6
D >	Audio cable	6-7
E >	Velcro® Mounting Dots (4)	5
F >	Silicone Feet	5
G >	Owner's Manual	—
	Registration Card	61
	Quick Guide	—



## Placement Considerations

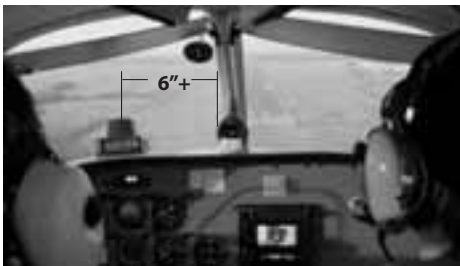

The preferred placement for XRX is on the glareshield, above the instrument panel. This configuration affords XRX the best possible sensitivity and accuracy. Also, position the unit close enough to your power source and to your audio headset connection, if you are going to hook up audio, to allow for proper hookup.



***Improper positioning of XRX on the instrument panel can result in errors in bearing.***

### Cable Routing

When routing the cable, place the cable as close to the glareshield as possible. Ensure no cabling reaches higher than the base of the antenna array. Avoid loops in the wire that may obstruct the XRX antenna array view.

### Keeping Clear of Obstructions

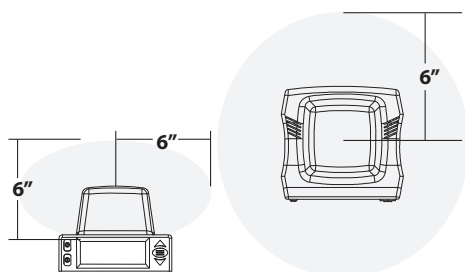

XRX needs an approximately 6" clear area around the antenna array with no obstructions to ensure the best sensitivity. This includes the magnetic compass, which must be at least 5" away from XRX for mutual calibration. This also includes the windscreen center pillar, GPS antennas, satellite weather antenna (especially those with a magnetic mount), etc. Adhering to this rule will avoid potential magnetic interference and provide the XRX antenna array with adequate reception.

### Rubber Feet

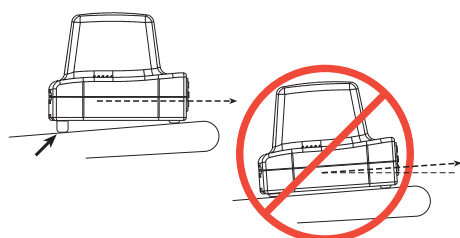

The PCAS unit must be set on your glare shield in a stance as close to level as possible. For your convenience, different sized silicone feet are provided in 1/4", 3/8" and 5/8" heights. This setup allows for a stance from level (using all four 1/4" feet) to a maximum of 3/8" differential using 1/4" feet on the front, and 5/8" feet in the back. These feet provide exceptional slip resistance on non-fabric glare-shields. Please ensure the unit is level to the normal cruise attitude of the aircraft. If not, compass accuracy could be affected.

### Velcro® Mounting Tabs

If additional slip resistance is required, or you are placing PCAS on a fabric-covered glare shield, use the four Velcro® mounting tabs to secure the unit to your glare shield, allowing for quick removal.



***Use of XRX in an automobile will result in inaccurate compass and traffic bearing. This is caused by the ferrous materials in the car's frame.***

### Connecting the Power

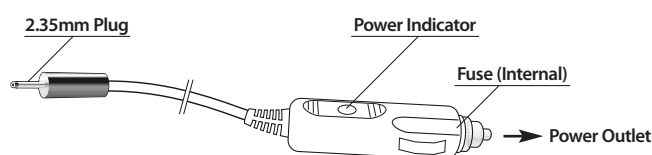

XRX is powered through your aircraft's "cigar-lighter" outlet\*, using the included power adapter. The adapter provided with your unit incorporates a built-in replaceable fuse for safety, and can handle between 12-40 volts DC.

The adapter is sensitive to proper polarity, but just in case of improper polarity, XRX is protected against reverse polarity. The connector is tip-positive (+) and outside negative (-) and should only be used in negative-ground systems. Please consult your aircraft manual if you are unsure of your type of aircraft electrical system.

\* Pilots flying newer Cessna models that do not have a cigar lighter outlet should call Zaon for alternative connections.

To replace the internal fuse:

- 1 > Disconnect both ends of the adapter
- 2 > Twist off the knurled end cap
- 3 > Replace the fuse with a 1- to 3-amp rated automobile-style quick-blow fuse
- 4 > Twist the knurled cap back into place

## Connecting to Permanent/Hardwired Power

In some instances, you may wish to power the unit directly from the avionics bus or other power source. Hardwiring the power supply will require a dedicated 1.0 amp minimum, in-line fuse. An internal line filter suppresses any undue transient noise on the power supply. Also, be sure to follow any FAA requirements concerning installation guidelines.

## Connecting the Audio

XRX incorporates two different audio methods: In-cabin audio (an internal audible tone generator) and female voice announcements over the Headset-Direct™ connection.

### Standard Headset-Direct™ Configuration

Your XRX comes with everything necessary to operate right out of the box, including the audio hookup cabling. To properly integrate the female voice audio alerts with that of your aircraft's system, use the included audio cable assembly. This configuration introduces the XRX voice alerts onto the intercom headset line. With this hookup, the voice alerts do not interfere with intercom transmissions or passenger audio, and maintains the original quality of your intercom system.

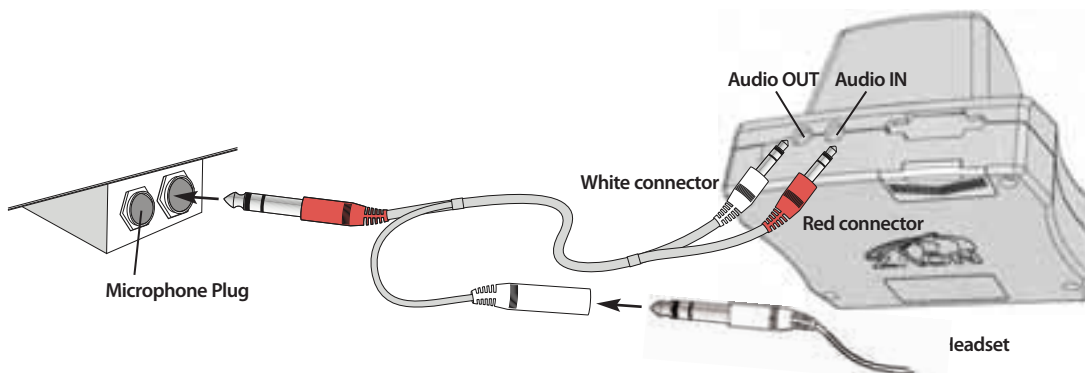

The red 1/8" connector on the back of the unit is Audio IN; the white 1/8" connector is Audio OUT.



***If one or both of the audio connectors becomes partially or fully disconnected, no audio will be heard, including intercom audio.***

## In-cabin Audio

To turn In-Cabin audio on or off, set Switch 6, Group A of the configuration switches.

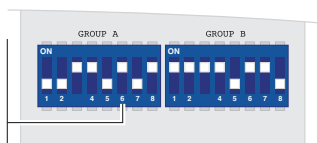

XRX incorporates an internal audible tone generator which can alert both the pilot and passengers of traffic threats and advisories. No external hookup is needed to take advantage of these audio cues. To turn this feature on or off, set Switch 6 in group A of the configuration switches to "ON" (see "Configuring the Audio" in the next section).

## Testing the Audio Output

To test the audio output of the XRX system, press the up or down arrow at the traffic page. **You will hear the In-Cabin beep, followed by the voice annunciation "Test" from the audio cable.** You may perform this step as many times as necessary to hear the test audio at louder or softer volumes. Your headset must be hooked up in order to hear the voice annunciation.

The audio test can also be performed through the General Information page in the Administrative menus. For more information, see "Additional Menus: Administrative Mode" in the "Buttons and Functions" chapter.

## Headset Adapters

The audio cable included with your unit works with GA-style connections with a separate 1/4" headset jack and 1/4" mini microphone jack. If your audio system is different from the standard GA configuration, several optional accessories are available to facilitate audio hookup, including Adapters for Bose® all-in-one connectors and U174 Helicopter-style plugs. To purchase, visit Zaon's website, call us directly, or ask your local avionics shop.

## Configuring the Audio

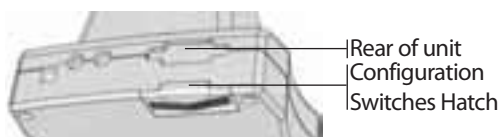

Because so many different types of intercoms exist, there are many different combinations of audio options. To allow XRX to correctly interface your audio system, you will need to configure your unit. On the bottom rear of the unit, a small hatch reveals two groups of switches. To

remove the hatch cover, use a small Phillips screwdriver to remove the retainer screw. To configure audio, change the settings of the switches in Group A. See "Configuration Switches" in the Appendices for more information.

The three options of audio configuration possible with XRX are impedance, mono/stereo selectivity, and ground isolation. If you are unsure of your aircraft's particulars, read the hints below for each category.

Option	Switch 1	Switch 2*	Switch 3*	Switch 4	How to Determine
300 Ω Impedance	ON				Check your intercom or audio panel for the proper impedance.
600 Ω Impedance	<b>OFF</b>				
Mono		ON	OFF		When in doubt, check your headset connector. 3 sections = stereo
Stereo		<b>OFF</b>	<b>ON</b>		
DC Ground Isolation (Stereo 2 wire)				OFF	Symptoms of wrong setting: sound too soft, squeal or hiss, no sound
DC Ground Connection (Stereo 3 wire)				<b>ON</b>	

**BOLD** indicates default settings. \* Switches 2 and 3 are mutually exclusive.

Table A: Audio-related configuration switch settings

Important notes about audio configuration:

- > If the audio level is too low or cannot be heard, try switching the impedance switch to the other setting.
- > **Placing both switches 2 & 3 to ON, or both to OFF may result in NO AUDIO OUTPUT.** For in-cabin audio, turn on switch 6 to enable, turn switch 6 off to disable. Switches 5, 7, and 8 are not used for audio configuration.

### Direct Wiring

Certain situations may benefit from an alternate audio hookup: wiring XRX directly into the aircraft system through the intercom auxiliary input, using an 1/8" jack (stereo or mono, as compatible) from the XRX audio OUT to the intercom AUX IN. In most cases, this will require hard-wiring and components not included with your XRX system. If your intercom isolates the pilot audio, this configuration will allow the XRX alerts to be heard only through the pilot's headset. If your intercom does not isolate the pilot audio, the XRX alerts may be able to be heard through each headset plugged into the aircraft intercom system. This is a function of the intercom or audio panel and not determined by XRX settings.

Please refer to the wiring schematic in Appendix E if you are hard wiring the unit to your intercom or audio panel.

### Antenna

XRX incorporates an internal highly-specialized directional antenna. For this reason, the unit should be placed on the glare shield of the aircraft to properly receive signals. Any structure must be at least 6 inches away from antenna such as a compass, portable GPS, etc. Please use common sense when placing your XRX. Metallic objects very near to the unit will affect bearing accuracy, as they would with any compass.

## Initial Calibration

The compass within XRX is calibrated at the factory, and no additional calibrations should be required under normal use. However, if you notice compass errors greater than 20° when compared to your aircraft compass in straight and level flight, you may need to recalibrate the XRX compass. This simple procedure is explained on page 45, "Compass Calibration".

## Pressurized Aircraft

XRX can be operated in a pressurized aircraft, but because of the internal altimeter, it must be set to pressurized mode. To set the unit to pressurized mode, set Switch 5 in group A of the configuration switches to "ON". For more information, see "Configuration Switches" section in the appendices.



***To use the pressurized mode, XRX requires you to have a local transponder with a minimum output of 100 watts and a maximum of 250 watts.***



Under normal circumstances, XRX uses the built-in altimeter to determine the local altitude and establish a base reference. The unit then compares the altitude of the target aircraft to this base reference to determine the relative altitude. In a pressurized aircraft, the built-in altimeter is rendered ineffective since it relies on static pressure readings, as found in a non-pressurized aircraft. In

pressurized mode, the unit bypasses the built-in altimeter and relies on the transmissions from your own transponder's encoder to establish the base reference. This can be an effective means of determining your own altitude, but you should be aware that a few limitations exist.



If no altitude is received from your transponder, you will see "NO ALT" on the screen and no traffic will be displayed. If this happens, you will need to reestablish a connection with your transponder. There are a few reasons why XRX may not always receive the altitude from your transponder, including:

- >Your transponder is not turned on, or is on but is not in "ALT" mode, or you do not have a transponder.
- > You are below RADAR coverage, a common occurrence when on the ground at an airport, or when not in line-of-sight of a RADAR station, and no other active system is interrogating your transponder.
- > Some squawk codes are coincidental altitude codes. If ATC assigns you a code ending with a "zero", there is a slight chance XRX will not be able to determine which code is an altitude code and which is a squawk code without the aid of an internal altimeter. To alleviate this problem if it happens, simply ask ATC for a code not ending in zero. For example, a squawk code of 0340 is also the same code as 800 feet.
- > The output of your transponder is less than 100 watts or greater than 250 watts.

## Controls & Functions

	Description	Page
1 >	Directional antenna array	8
2 >	Power button	37
3 >	Mute button	37
4 >	Primary Aircraft	12
5 >	Secondary Aircraft #1	12
6 >	Secondary Aircraft #2	12
7 >	Up button	37
8 >	Menu button	37
9 >	Down button	37
10 >	Volume level indicator	37
11 >	Local Heading	14
12 >	Local Altitude	14
13 >	Power Input (12-40 VDC)	5
14 >	Audio Out	7
15 >	Audio In	6
16 >	RS-232 Connection	42, 59
17 >	Config. switches hatch	59

Front View

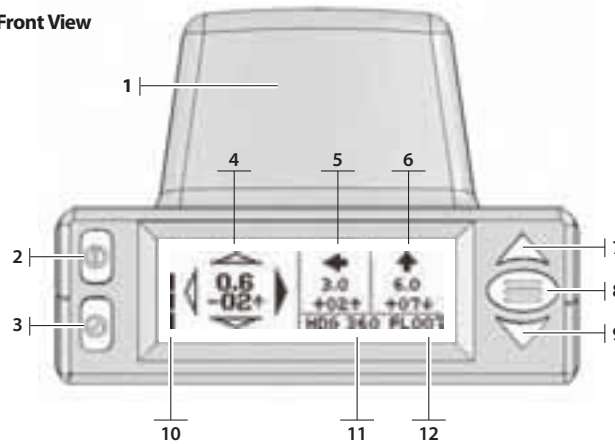

Rear / Bottom View

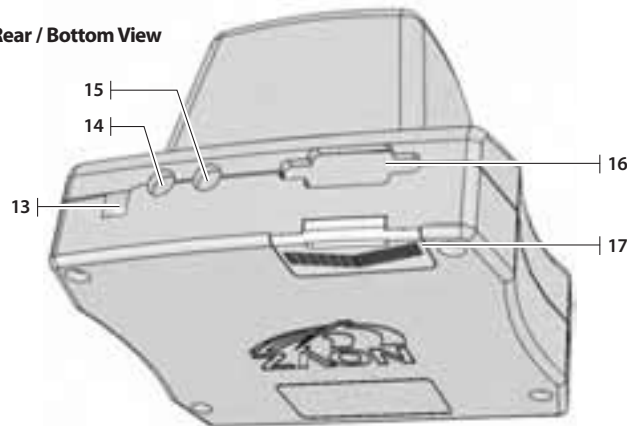

## Carry Case

A hard carrying case is included for your XRX. This case is designed to carry all of your accessories and to protect your XRX from damage and the elements. The carrying case is not waterproof. Care is needed when leaving the case exposed to the elements.

To clean the carrying case, use a towel and a minor detergent solution or glass cleaner. Do not use harsh abrasives or chemical solutions as this will damage the case.



# Understanding PCAS

## What is PCAS?

PCAS, which stands for Portable Collision Avoidance System, is a trademark of Zoon Flight Systems for technology similar in function to TCAS (Traffic and Collision Avoidance System). TCAS is the industry standard for commercial collision avoidance systems. The original PCAS technology was developed by Zoon in 1999. Now, the MRX/XRX line of collision avoidance systems incorporates the fourth generation of PCAS technology. Through this technology, transponder-equipped aircraft are detected and ranged, and the altitude is decoded. PCAS G4 technology has advanced to the point that highly accurate range, relative altitude, and quadrant direction can be accurately detected in a portable, all-in-one cockpit device.

## What does XRX show?

Reading your XRX is simple and straightforward if you understand the concepts behind its design and operation. XRX operation can be broken into two areas of thought and use: traffic detection and traffic alerts. It is important to know how to visualize the detection window around you.

### The Detection Window

Traffic information takes three forms, or “dimensions”. The easiest way to understand this is to think of a target aircraft in three dimensional space.

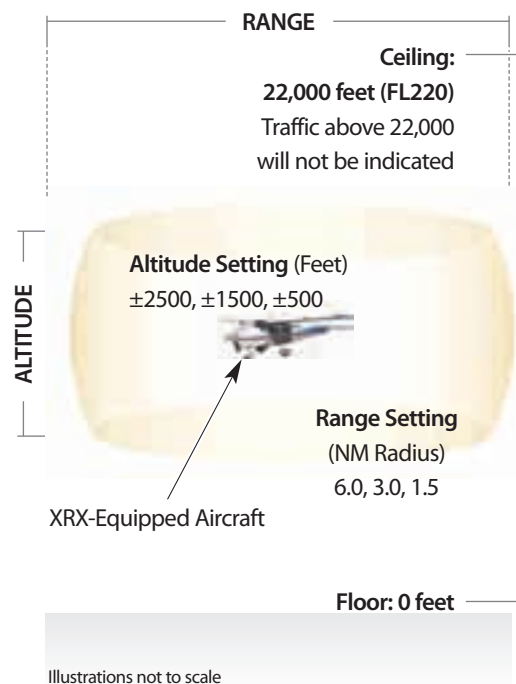

The first dimension is range, or how far away the aircraft is. Imagine a sphere with your XRX-equipped aircraft in the middle. With only range to go by, the surface area of the sphere represents all of the possible points at which the aircraft could be. The radius, or size, of the sphere is determined by the range, or how far away the target aircraft is.

The second dimension, relative altitude, tells us how far above or below our horizontal plane the aircraft is. Once we know range and relative altitude, the sphere of possible points is reduced to a ring, positioned above us or below us, depending on the relative altitude of the aircraft. The third dimension is direction. Once we take the ring and add the direction “dimension”, we’ve reduced the possible points where a threat aircraft could be down to a point.

In other words, range, relative altitude, and direction together can tell us the X, Y and Z coordinates of the threat aircraft in three-dimensional space around us, or relative to our position.



**By default, XRX is set to 3 NM and +/- 1500 feet at startup.**

The detection window surrounding your aircraft in flight can best be visualized by imagining a “Bubble of Awareness” surrounding your aircraft. XRX will display any aircraft within this detection window. The “bubble of awareness” can be shaped to meet the needs of your current flying situation.

The width of the bubble represents and is defined by range; the height is defined by altitude. Both the altitude limits and range limits can be set independently of each other by the pilot.

## The Traffic Screen

When XRX detects aircraft within the detection window, the following information is displayed on the traffic screen:

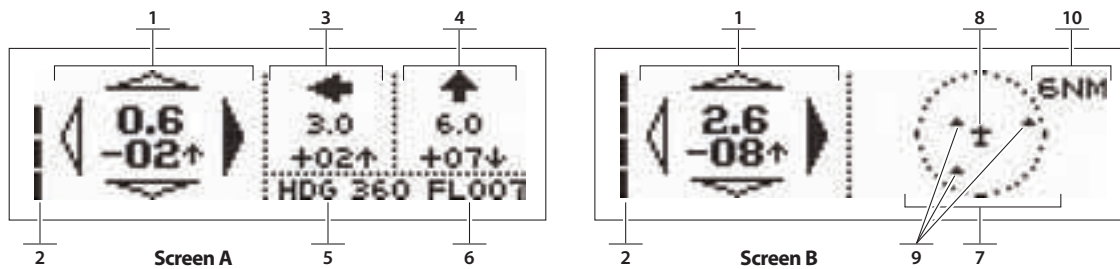

### Screen A & B Information

- 1 > Primary Aircraft
- 2 > Volume indicator

### Screen A Only

- 3 > Secondary Aircraft #1
- 4 > Secondary Aircraft #2
- 5 > Local heading
- 6 > Local altitude

### Screen B Only

- 7 > Overhead traffic view - Range setting: 6NM, 3NM, 1NM
- 8 > Your aircraft
- 9 > Target aircraft (maximum of 3)
- 10 > Range setting

### Target Information

- A > Direction relative to your bearing: indicated by the compass rose
- B > Range in nautical miles
- C > Altitude relative to your local altitude: aircraft is above you (+) or below you (-)
- D > Vertical Trend: Ascending (↑) or descending (↓)

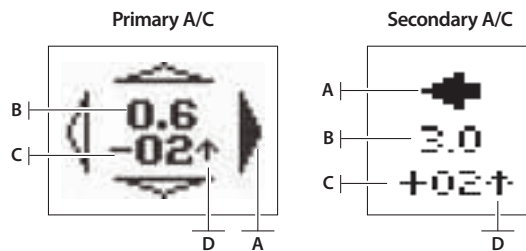

To switch between screens, press **menu/select**, choose **Screen**, then select **Screen A** or **Screen B**. Press **mute** to exit to traffic screen (see page 43, "Menu 5: Screen Options" for more details).

Aircraft is...	Primary	Secondary
To your left		
In front of you		
To your right		
Behind you		

Direction is indicated through the compass rose for the primary aircraft, or by an arrow for secondary aircraft (see chart). It is important to note that direction is not cardinal points (N, S, E, W) but is relative to your heading. An arrow up indicates traffic is in front of you. In the example shown, the primary (closest) aircraft is 2.0 NM away, 600 feet above you, and descending.

In addition to the four directions illustrated, 45° angles are also represented for the **primary** aircraft by indicating two adjoining directions. This indicates an aircraft between the front and left of you.



Table B: Direction Indicators

Other important things to know about the traffic screen:

- > "No traffic" is indicated by blank areas in both the range and altitude sections of the display, and no directional information. This is true for both the primary traffic and secondary traffic areas.
- > Aircraft at the same altitude is indicated by "00" for the relative altitude.
- > In the secondary threat positions (1 and 2), traffic bearing is displayed in 90° increments only. Only the primary threat bearing can be shown in 45° increments.

### Vertical Trend

In addition to relative altitude of the target aircraft, XRX also displays the vertical trend, or if the aircraft is climbing or ascending. Vertical trend is indicated by or . Monitoring the vertical trend will assist in deciding if the aircraft is a threat or not. Traffic that is not climbing or descending will not indicate vertical trend.



**Vertical trend is based on the target's actual altitude ascent/descent rate, not the relative altitude change rate.**

## Local Information

In the lower right corner of the traffic screen, the local heading and local altitude are displayed.

**HDG 360 FL 037**

Local altitude is displayed in flight levels (indicated by "FL"). The primary source for this information is the unit's own built-in pressure altimeter and is verified when possible by receiving what your transponder encoder is transmitting. It is important to note the local altitude is pressure altitude, not necessarily your actual altitude. This is factory calibrated and should not need adjusting. However, adjustments are possible using the Admin menus, covered later in this chapter.

The magnetic heading you are facing or traveling is also displayed, indicated by "HDG". This information is taken from the on-board compass and is delivered in 10° increments. To calibrate the compass, see "Calibrating the Compass", later in this chapter.



***Traffic may change positions on the screen as time passes and the priority of each intruder changes.***

## Ground Mode vs. Flight Mode

Like some TCAS systems, XRX gives you the option upon startup of operating in ground mode or flight mode. If the unit is in **Ground Mode**, aircraft below you and up to 200 feet above you are ignored. This is useful when on the ground and you wish to ignore the aircraft taxiing around you in favor of detecting aircraft in the pattern or on final approach. As soon as you climb (or descend) 200 feet, it will automatically switch to Flight Mode. Ground Mode reduces ground clutter, or the detection of aircraft at the airport with their transponders turned on. In **Flight Mode**, the unit will detect aircraft both above and below you.

To set the unit in Ground Mode, turn the unit on and press the menu button during the startup sequence. To set the unit to Flight Mode, press the up arrow during this sequence. If no button is pressed during the startup sequence, the unit will automatically default to Ground Mode after 35 seconds.

If in Ground Mode, the unit will automatically switch to Flight Mode once 200 feet of climb is detected from the time you turned the unit on. If you turn on or restart the unit in Ground Mode while in flight, the unit will not detect aircraft below you and up to 200 feet above you until you climb 200 feet. If this happens, restart the unit in Flight Mode by turning the unit off, then on, then pressing the up arrow instead of the menu button at the warning screen.



***If XRX is in Ground Mode, aircraft below and up to 200 feet above you will be ignored in order to eliminate the detection of aircraft on the ground.***

## Threat Prioritizing

The primary aircraft is chosen by examining the following criteria:

- > Threat aircraft relative altitude (vertical separation)
- > Threat aircraft vertical trend (ascending or descending over time)
- > Local aircraft vertical trend
- > Range to target, if two or more aircraft match with regard to the above criteria

Following the rule that “accidents can only occur at your altitude,” the aircraft with the least vertical separation, or where the relative altitude is less than any other, is determined to be the primary aircraft. Up to two additional aircraft are displayed in the secondary aircraft positions. However vertical trend is also used to prioritize when two aircraft are on converging paths and both are within  $\pm 1000$  feet. For example, if you are descending and another aircraft is below (within -1000 feet), it will be the primary threat, even if another aircraft is closer in range and/or relative altitude above you and level.

Should XRX determine that a new aircraft has become a greater threat than the one currently being displayed, it will be displayed in the Primary Threat area. It is not uncommon to see aircraft changing positions on the screen as time passes. See “Example Flight Scenarios” later in this chapter.

## Resolution & Accuracy

With regard to the **range** of the target aircraft, accuracy increases exponentially the closer the threat gets to your XRX. Range can be determined by examining the amplitude of the received transponder signal and cross checking it against the other aircraft’s altitude. For example, an aircraft 5,000 feet above you would not show less than 1.0 NM away. This helps ensure advisories issued are accurate given the true range to the other aircraft. Accuracy and resolution work hand-in-hand. For the XRX, traffic at a range greater than 3.0 miles is displayed in whole mile increments. Between 2.0-2.8 NM, the power output is far enough “up” the logarithmic scale that mileage can be accurately computed in 0.2 mile increments. Under 2.0 miles, traffic is close enough to be computed in 0.1 mile increments.

**Altitude** is set at 100-ft increments since this is the digital resolution set by transponder encoders.

**Bearing** accuracy is dependent on the compass and rate of turn. Turns greater than 10° per second can greatly affect the bearing accuracy.

Range Resolution (NM)		Altitude Resolution
3.0 to 6.0:	Whole mile increments (i.e. 4.0)	Given in 100-ft. increments, relative to host aircraft altitude (i.e. 600 ft. above is shown as +06)
2.0 to 2.8:	0.2-mile increments (i.e. 2.4)	
0.4 to 1.9:	0.1-mile increments (i.e. 1.3)	

Table C: Range and Altitude Resolution

## Traffic Advisories and Alerts

There is a difference between traffic **detection**, as defined in the previous section, and traffic **alerts** (threats). XRX will not alert you to traffic that does not fall within your specified threat detection envelope, regardless of whether an indication of traffic appears in the display window.

XRX incorporates both voice announcements through the headset, a high-volume tone generator, and quick display flash to alert you of an impending threat. Two levels of threats are given: traffic **advisories** and traffic **alerts**.

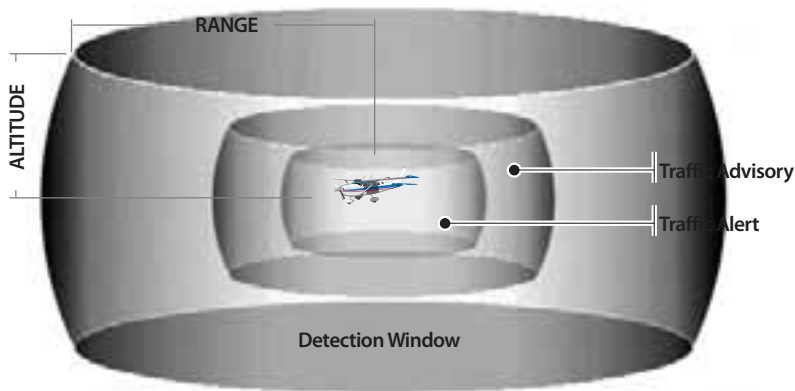

The points at which traffic advisories and traffic alerts are given depend on the range to target and if the aircraft is converging with you or not. The threshold within which threats are considered is determined by the range setting, as shown in the table below. Overall, when the detection window is decreased in size by scaling down the range and altitude, the alert thresholds are

reduced as well.

Level	Audio	Range Setting	Converging Traffic is within Range...	...and Relative Altitude is less than...
Advisory	Headset: "Traffic advisory. Monitor Closure Rate" Beeps: 2	6 NM	2.0 NM	±1000 ft.
		3 NM	1.0 NM	±1000 ft.
		1 NM	0.6 NM	±500 ft.
Alert	Headset: "Traffic alert. Obtain visual contact" Beeps: 4	6 NM	0.7 NM	±700 ft.
		3 NM	0.6 NM	±600 ft.
		1 NM	0.3 NM	±500 ft.

Table D: Advisory and Alert Thresholds. Please note the following:

- > In a case where Altitude is set to ±500 ft and Range is set to 6 or 3 NM, no Traffic Advisories would be given. Because the threshold for these Range settings is greater than 500 ft., the system would "skip over" the Advisory and give an Alert warning.
- > Each of the top three traffic threats are evaluated independently against the Traffic Advisory and Traffic Threat criteria indicated in the table above. This means that an advisory or alert may be given for an aircraft not in the primary traffic location if it falls within the threshold(s).



***Alerts and advisories are determined by the range of the aircraft converging, and what range setting you have selected.***

## How does XRX work?

XRX is a stand-alone, passive system. Passive systems are different from active systems such as TCAS, Skywatch®, etc. Active systems can be found in commercial airliners, corporate jets, and higher-end general aviation aircraft. They actively interrogate aircraft transponders within a specific range. Passive systems like your XRX listen for the replies to these interrogations, as well as ground-based RADAR interrogations.

### How is direction obtained?

The key to providing directional information is the antenna design. XRX uses a specially designed antenna which uses a combination of signal amplitude and/or phase cancellation, which is the only way to accurately detect direction from inside the cockpit. Other methods of directional detection do exist, but antenna array installation is required. Difficulties with detection inside the aircraft include airframe echoes, multipath, phase cancellation, and signal path loss due to airframe shadowing. The XRX design overcomes most of these issues. However, direction resolution is limited to 45° increments. Inside your XRX is a highly-specialized antenna array. This array is made up of four precision tuned directional antenna elements which are coupled to four individual super heterodyne RF receivers. Several years of testing and the use of our custom-designed RF anechoic chamber allow the XRX to overcome reception issues and accommodate a wide range of airframe types. The traffic bearing information displayed is directly related to the internal solid-state compass to accommodate changes in heading so that at any given moment the bearing you see is relative to your heading. This design allows the unit to “hear” which direction the aircraft is approaching and display the information on the screen. Multiple aircraft are tracked at once using this method.

Bearing information shown is directly related to the angle at which your XRX system is placed upon your glare shield. Changing the forward angle of the unit greater than 20° to accommodate viewing is not recommended without using the 45° screen option (see page 43, “Screen Options”).



***Changing the angle of the unit greater than 20 degrees to accommodate viewing is not recommended without using the 45-degree screen option.***

## The Importance of Relative Information

The key to displaying smooth, understandable traffic information is relativity. If the information is always relative to your aircraft, you are your own point of reference. Range is relative to your location, as is the relative altitude (ie +600 above your altitude) and relative bearing (ie: to your right). For instance, if only the altitude of the other aircraft is known, you would have to find out your own altitude by another glance at your altimeter, then do the math. Likewise, to find out the target’s relative bearing, you must glance at your own heading indicator. However, XRX contains these instruments and will do these calculations for you. You will see a live, relative representation that requires no translation, whenever you glance at the XRX screen.

### Built-in Compass for Relative Bearing

Target aircraft transponders are not always broadcasting. Therefore, if a target is straight ahead and you initiate a turn, the unit would continue to erroneously indicate the aircraft as straight ahead until the other transponder broadcasts again. Since the XRX incorporates a built-in compass, the unit knows you have changed your heading and can accurately recalculate the relative position of the other aircraft. This is applicable to any aircraft within detection range. It is very important that the compass be calibrated accurately to ensure overall bearing accuracy (See page 46, "Compass Calibration").

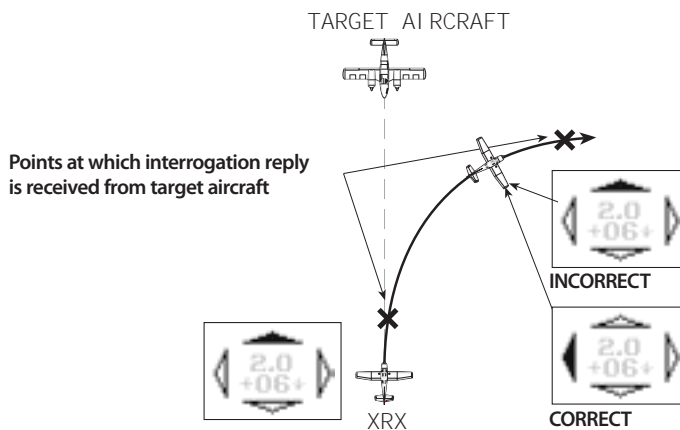

**Without** the accuracy of an internal compass, the traffic would still show straight ahead until the next reply was received.

**With** XRX's built-in compass, XRX will correctly and smoothly track traffic by continually updating relative positioning, even between replies. Notice how the target aircraft has descended further (XRX watches the trend) and now shows to the left.

### Built-in Altimeter for Relative Altitude

One of the features that makes PCAS superior is the built-in altimeter, which establishes an accurate base reference for the relative altitude. Because the altitude information is relative to your altitude, the unit must know your local altitude at all times. Under normal conditions, the following occurs:

- 1 > Your transponder's encoder broadcasts your local pressure altitude (set at 29.92").
- 2 > XRX intercepts and decodes your local altitude.
- 3 > XRX compares this to the altitude from the built-in pressure altimeter to ensure accuracy.
- 4 > If acceptable, XRX uses the transponder altitude as a base reference.
- 5 > XRX accurately presents relative altitude information for traffic.

Many times, the local altitude is not available from your transponder, or cannot be accurately relied on. This is normal for all collision avoidance, and XRX will automatically provide a work-around. In these cases, the following occurs:

- 1 > XRX uses the built-in pressure altimeter as a base reference.
- 2 > XRX accurately presents relative altitude information for traffic.

As you can see, the most important thing to note is that your XRX will present you with accurate relative altitude information at all times. It is recommended that the altimeter be checked periodically by setting 29.92 in your altimeter and



comparing this to the local altitude the XRX is showing when no transponder is present. Matching these will ensure overall accuracy (See page 48, "Altimeter Calibration").

Portable collision avoidance avionics which display altitude information must rely on a secondary source for altitude rather than the host transponder only. Competitive units which do not incorporate an altimeter will experience the following problems.

Here are the top seven reasons why an internal altimeter must be present:

**Scenario 1: "Image Altitude"—Squawk vs. Altitude Code Confusion**

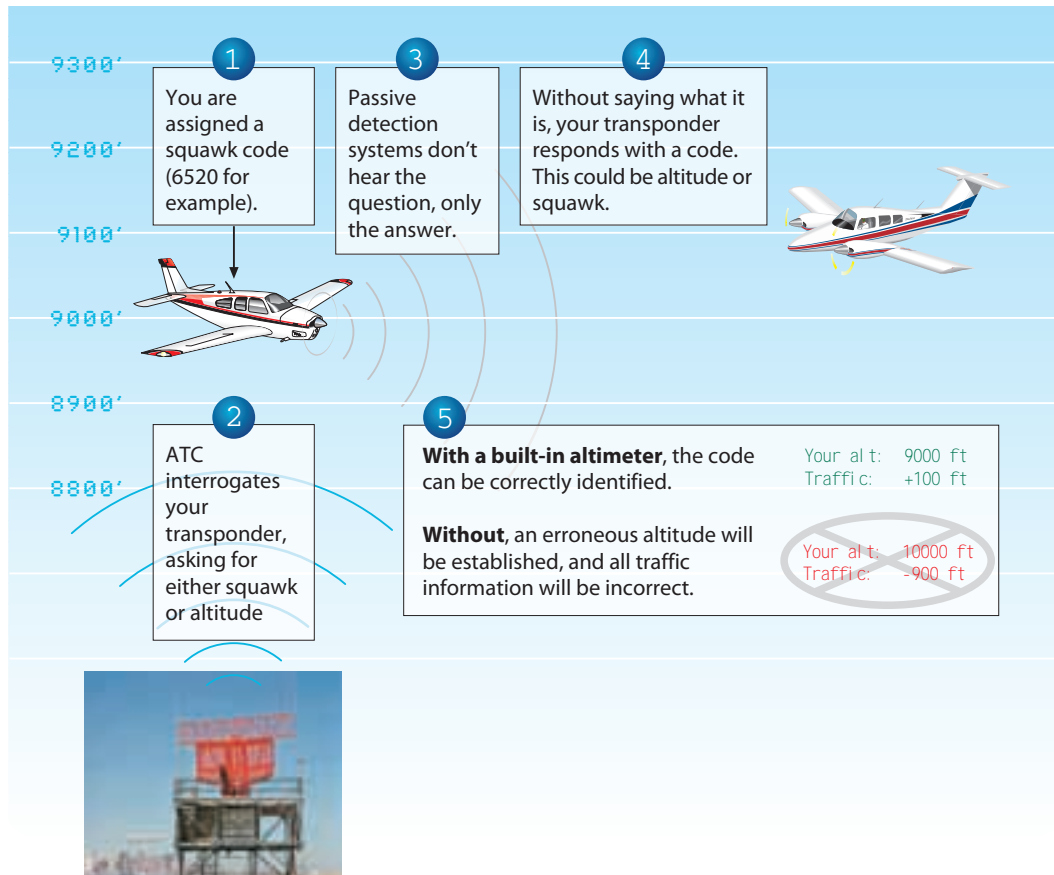

- > **Problem:** Both altitude and squawk code are encoded in the same fashion. Without an internal altimeter, errors will result if squawking one of the hundreds of possible IFR or ATC codes because the transponder is sending "image altitude", a squawk code that happens to match up with an altitude code.
- > **Solution:** PCAS recognizes the hundreds of possible squawk codes possible which can be confused as an altitude code. The internal altimeter allows PCAS to select the correct altitude in this situation.
- > How can ATC tell the difference? On a different frequency, ATC is interrogating and asking for either squawk or altitude. If a Mode A (squawk) interrogation is issued, a Mode A reply is expected, and the pulses will be decoded that way. Likewise, if a Mode C (altitude) request is made, the data received from the aircraft will be calculated as altitude.

**Scenario 2: Temporary RADAR Shadows**

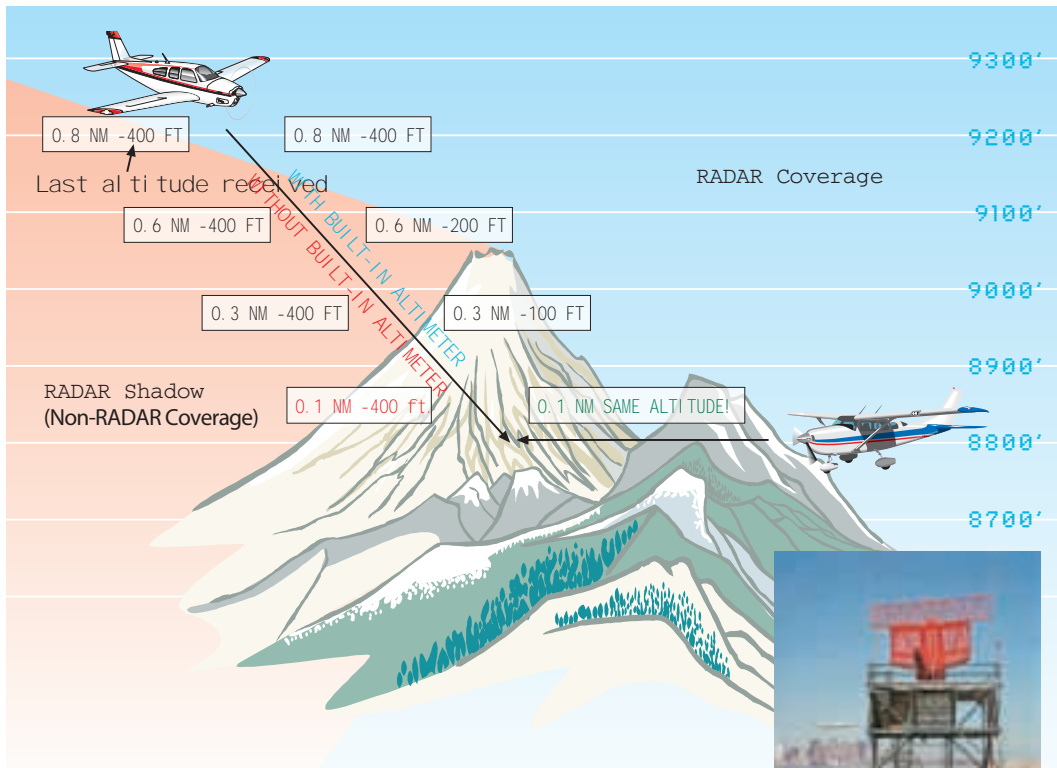

- > **Problem:** When entering a temporary RADAR shadow, without an internal altimeter, the last received altitude would be carried into the shadow area, resulting in erroneous traffic information and potentially dangerous results.
- > **Solution:** PCAS recognizes when the transponder stops sending altitude information and uses the internal altimeter. In this example, the unit will display converging altitudes.
- > RADAR shadows exist in many areas. The above example is only one possibility of RADAR shadowing. Less dramatic shadowing can occur in other situations. When turning final to land, if the antenna on the bottom of the fuselage is turned away from the ground RADAR station, momentary shadowing may occur. In this critical moment, the internal altimeter will take over and allow for precise traffic information. Without this, the same dramatic results above may occur.

**Scenario 3: Aircraft Below RADAR Coverage**

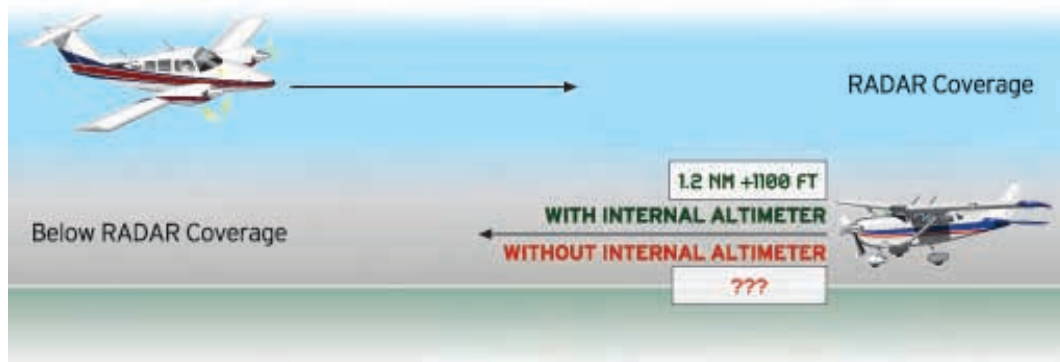

- > **Problem:** When flying below RADAR coverage, no local altitude information can be gathered.
- > **Solution:** Again, the internal altimeter allows PCAS to function normally, establishing a base reference for your altitude and displaying relative altitude for traffic.

**Scenario 4: No Transponder (ie Glider) or Transponder Not In ALT Mode**

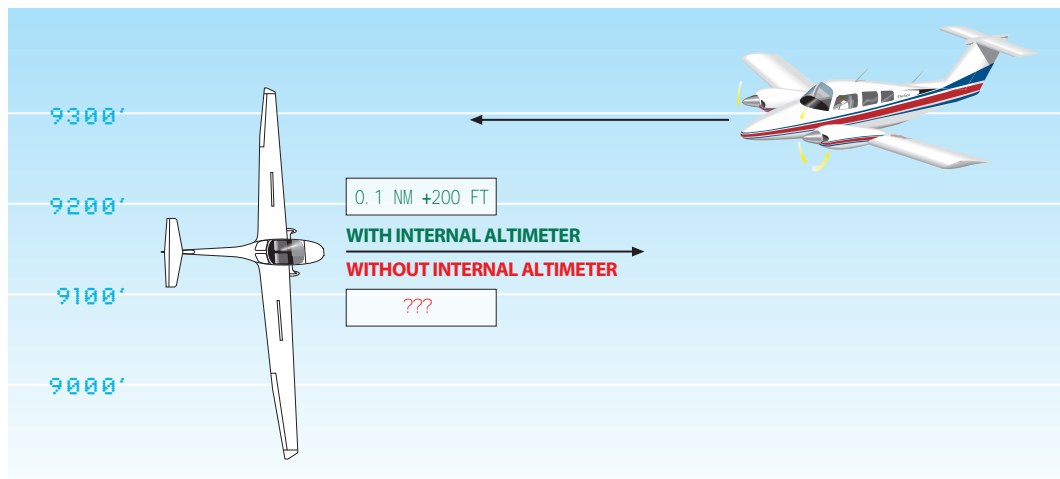

- > **Problem:** Another problem with relying only on your transponder for altitude information exists if you don't have a transponder or you forget to turn your transponder to the "ALT" mode.
- > **Solution:** PCAS functions normally when depending on only the internal altimeter, making it the only collision avoidance system available for gliders. PCAS will also alert you if you forgot to turn your transponder on.

**Scenario 5: Multipath Anomaly**

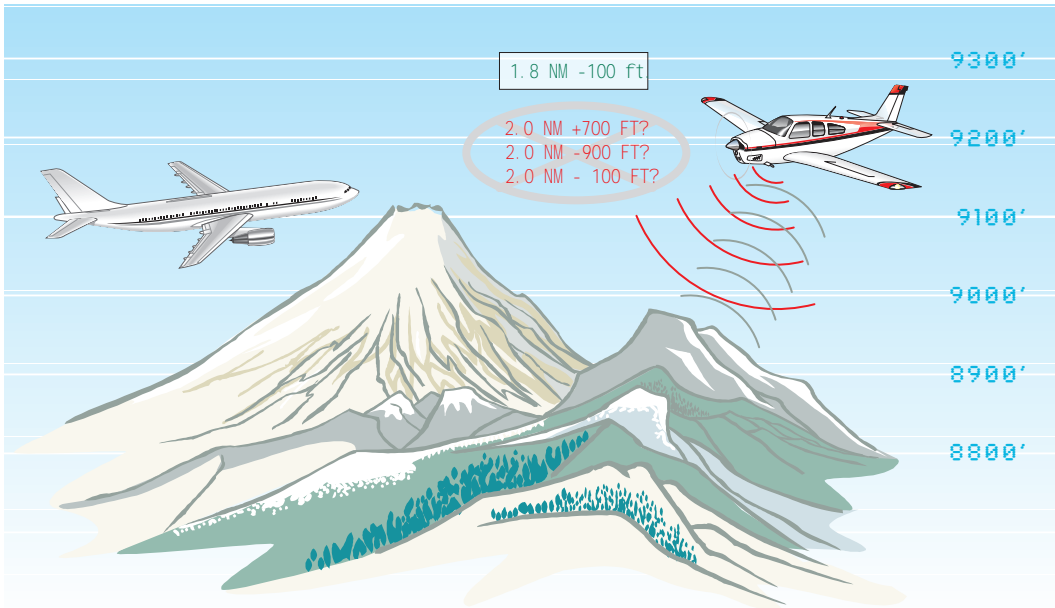

- > **Problem:** Relying only on the transponder for altitude can result in situations where the transponder's own signal is reflected, and delayed overlaps distort the overall signal, leaving no clear altitude code.
- > **Solution:** PCAS recognizes the distorted echo of the transponder signal, and the internal altimeter error correction logic determines the correct altitude.

**Scenario 6: Nearby Transponder Confusion**

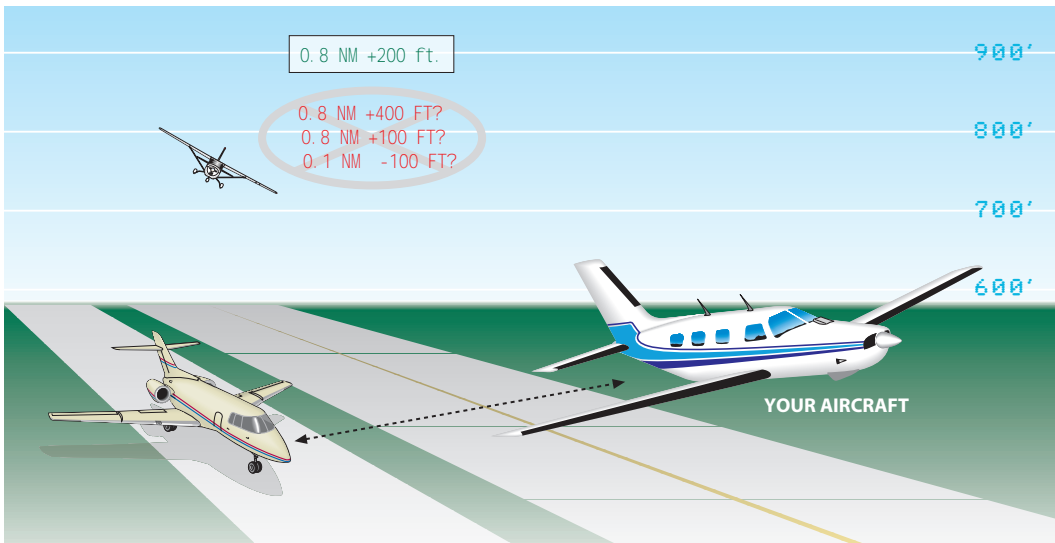

- > **Problem:** In a crowded airport environment, especially on final or takeoff, confusion over which aircraft's transponder altitude to use would be an obvious problem without an internal altimeter.
- > **Solution:** PCAS recognizes other transponders as "Not Mine" with altimeter logic algorithms.

**Scenario 7: Mode A Transponders**

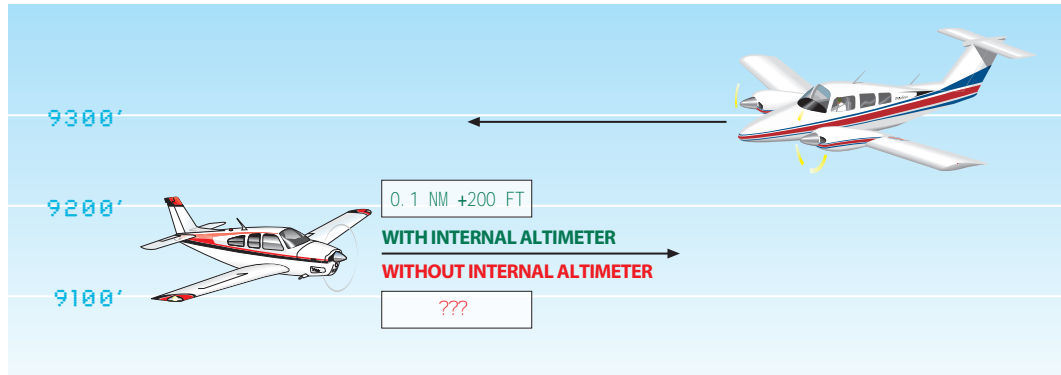

- > **Problem:** Similar to scenario four above, aircraft that do not have a Mode C transponder cannot use a device without an internal altimeter.
- > **Solution:** Again, the internal altimeter sets a reference for proper traffic detection.

**How altitude is accurately determined inside a cockpit**

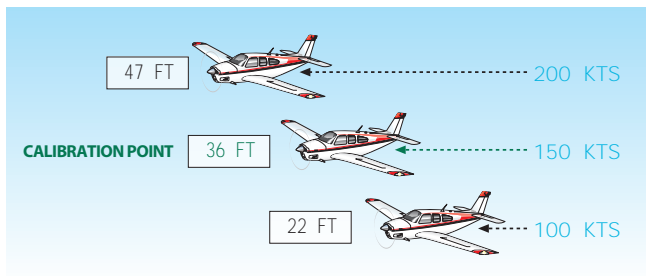

Once airborne, PCAS uses corrective altitude algorithms to adjust for the minor Bernoulli effects encountered. While this difference in altitude is minute, it is still accounted for. The result is an internal altimeter as accurate as altitude encoders.

To test this, turn on the alternate static source to pull static pressure from inside the cabin. Watch your altimeter. The difference should be around +36 ft.

## What does XRX detect exactly?

To explain how the system works, consider the following illustrations:

- 1 > To start the cycle, an interrogation is sent out from ground-based RADAR stations and/or TCAS or other actively interrogating systems in your area. This signal is sent on 1030 MHz. For TCAS, this interrogation range can have a radius of 40 miles or more from the interrogation source. The Ground RADAR range can be 200 miles or more.

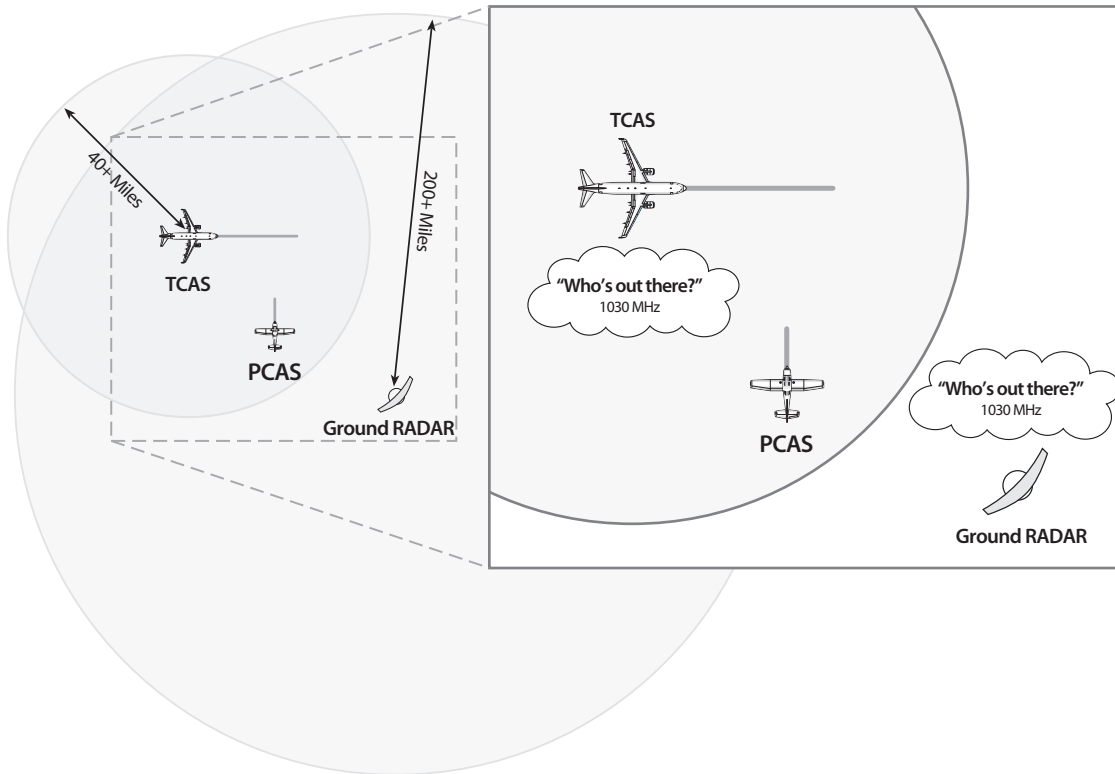

- 2 > The transponder on any aircraft within range of the interrogation replies on 1090 MHz with their squawk code (known as Mode A) and altitude code (or Mode C). The altitude information is sent in an encoded format.

Mode S transponders also reply on this frequency, and encoded within the Mode S transmission is the Mode A (squawk) and Mode C (altitude) information.

Military aircraft also respond on this frequency but use a different transmission protocol (see Step 3).

Your aircraft's transponder should also reply. However, PCAS watches for this signal and will not report it as a threat aircraft. The unit may use this information to establish base altitude for use in step 4.

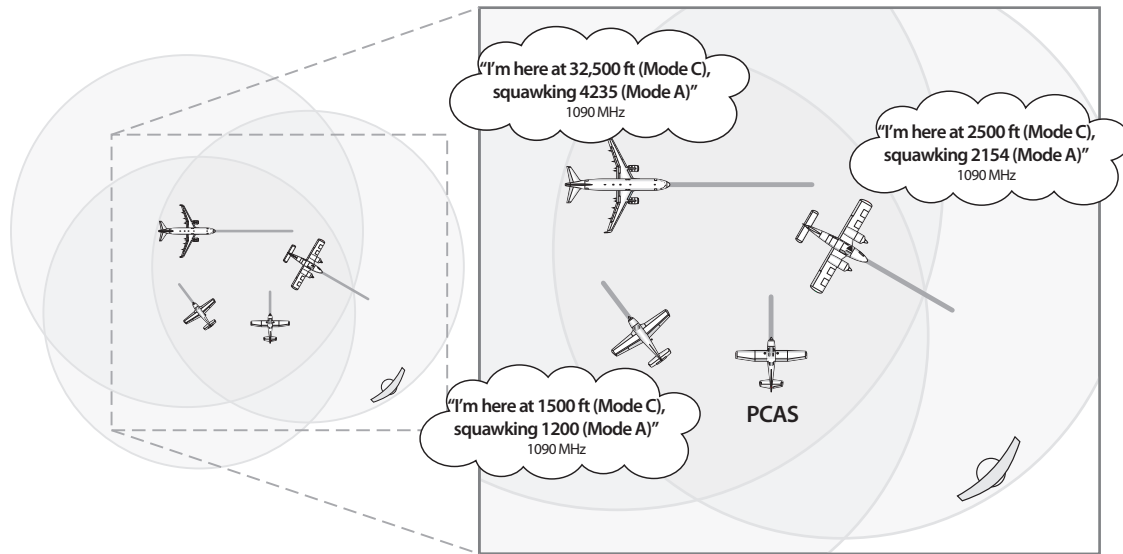

- 3 > Any aircraft reply within the XRX detection window (maximum 6 miles) will be received. The range is computed, the altitude code is decoded, and the signal angle-of-arrival is determined. PCAS will recognize interrogations from TCAS, Skywatch, and any other "active" system, military protocols, and Mode S transmissions.
- 4 > The altitude of the aircraft (in the example, 2500 ft.) is compared to your local altitude (i.e., 1500 ft.) and the relative altitude is calculated (i.e., 1000 ft. above you). With relative direction, altitude and range determined, PCAS displays this information and stores it in memory.

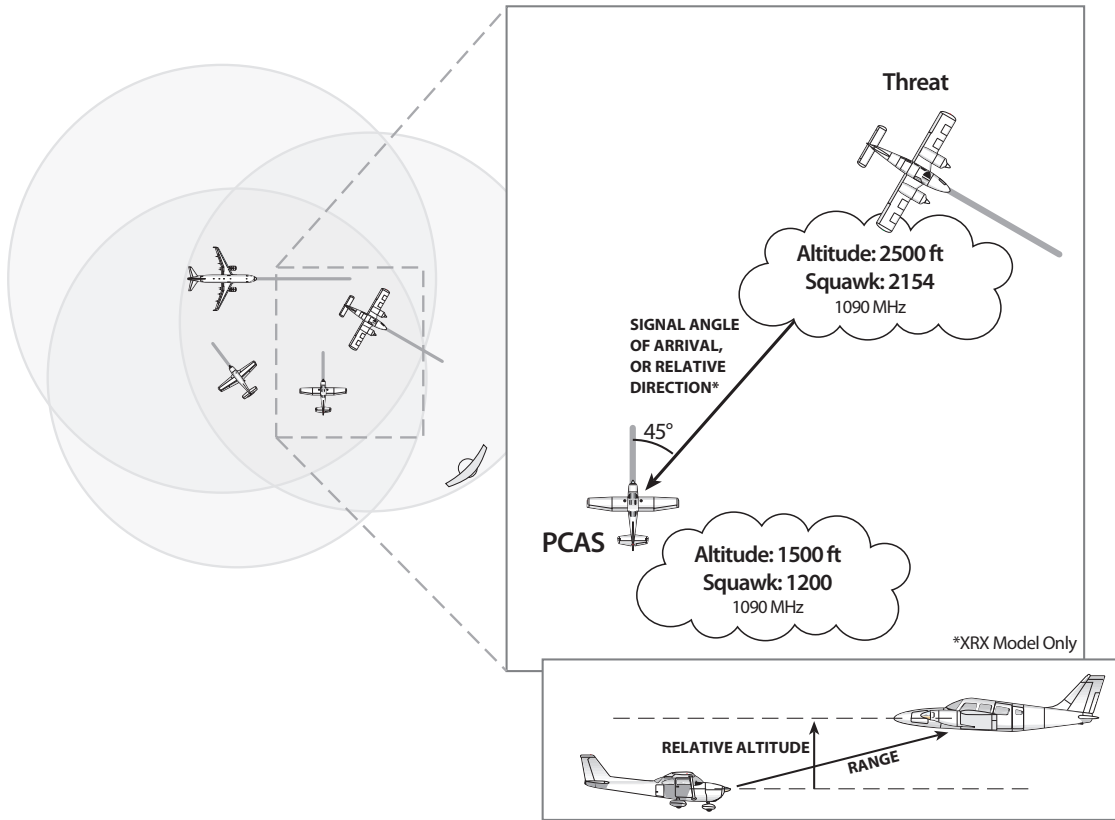

- 5 > If additional aircraft are within detection range, the above process is repeated for each aircraft. The top threat is displayed on the left of the traffic screen, and on Screen A, the second and third aircraft are displayed on the right.

The greatest threat is determined by looking at aircraft within the detection window you set up and comparing primarily the vertical separation ( $\pm$  relative altitude), and secondarily the range to the aircraft currently being displayed. PCAS uses proprietary algorithms to determine which of two or more aircraft is a greater threat. See flight scenarios later in this chapter for more information.

## Example Flight Scenarios

Many different flight scenarios exist, of course, but you will find common situations that prevail in everyday flight. The examples on the following pages illustrate what to expect in these common situations and how to visualize the aircraft around you.



**Example 1: A Single Aircraft**

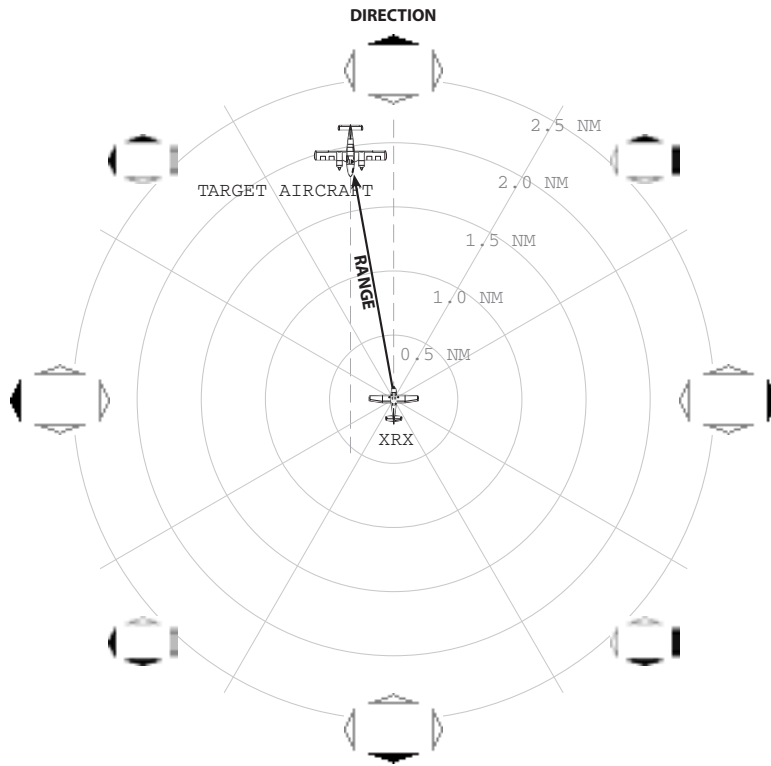

In this example, there is only one aircraft in the detection window. If the aircraft is 1.9 NM away and 300 feet above and descending, this is what the XRX screen will show. This is an alert situation. An attempt should be made to visually identify this aircraft as soon as possible.

Use the information XRX is giving you to alter your course if the situation warrants.

The ascent/descent indicator is based on the target aircraft's actual climb or descend trend, not the relative difference in altitude between you and the target. Because of this, you may see the down arrow, meaning the aircraft is descending, even if you are also descending.

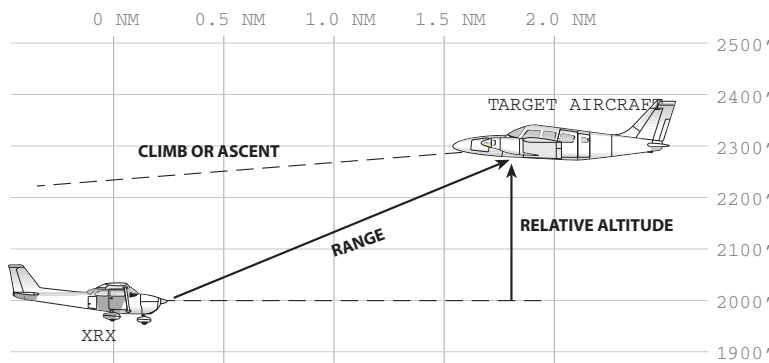

### Example 2: Prioritizing

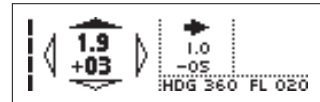
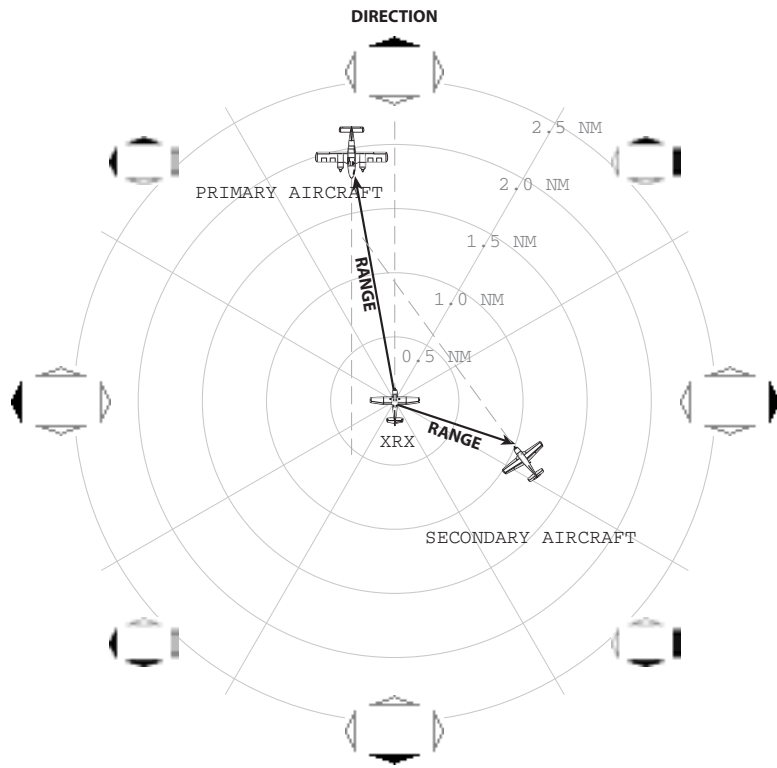

If another aircraft is added to create this scenario, the first thought might be the new, “closer” aircraft might be the greatest threat, and thus be priority 1. But upon further study, notice the aircraft is 500 feet below, whereas the other aircraft is only 300 feet above.

XRX prioritizes based on altitude first, but does take into consideration the ascent/descent rate, as shown in the next scenario, as well as range in certain circumstances. However, the obvious notion that accidents only occur at your altitude holds true, and the aircraft with the least amount of vertical separation will take priority over others.

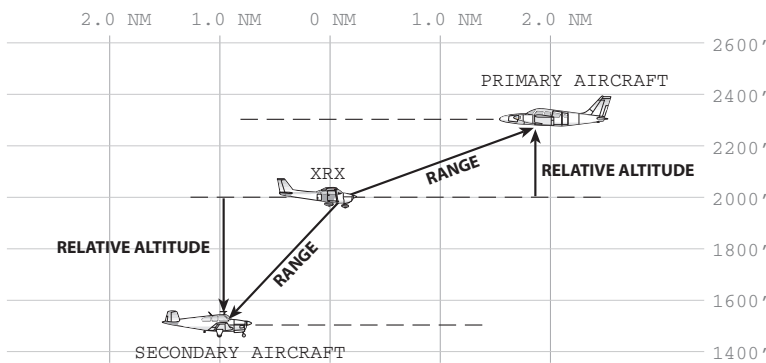

### Example 3: Prioritizing Close Altitudes

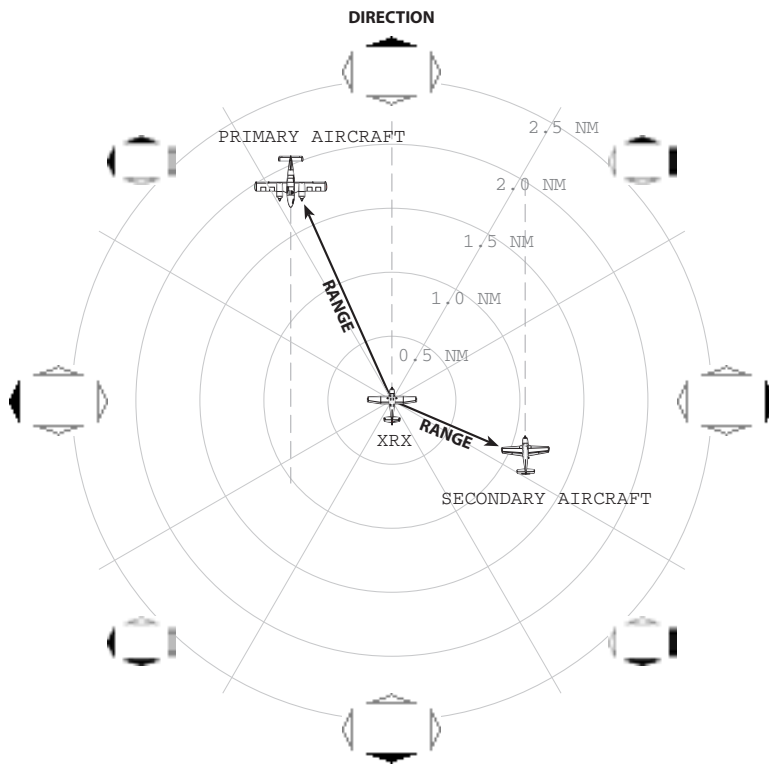

Vertical trend plays a large part in the prioritizing of aircraft threats. In this example, an aircraft is 200 feet above us and climbing, and another is 700 feet below and level. Because we are descending, the aircraft below is a greater threat, even though both the range and the vertical separation are greater than the one above.

The same would be true if the aircraft below was climbing and we were level or descending.

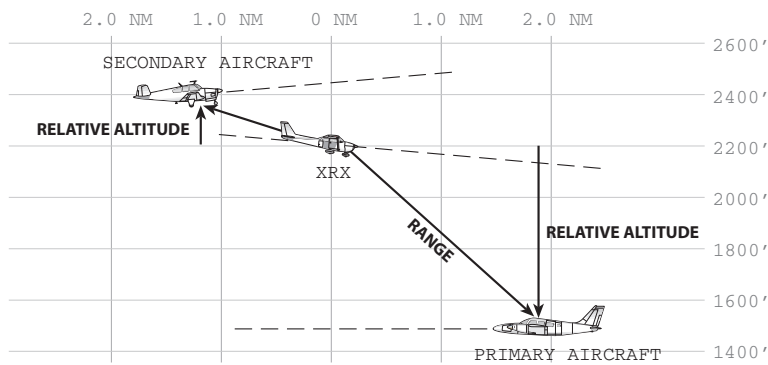

### Example 4: Same Altitude for Multiple Aircraft

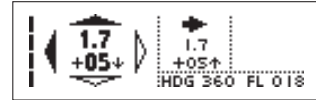
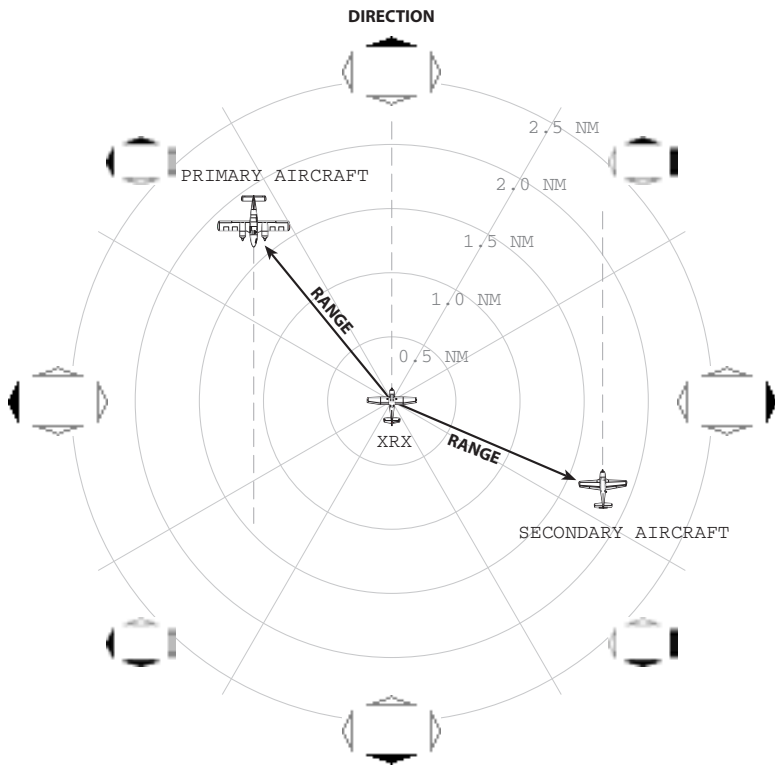

If two aircraft are at the same altitude, range will be used to prioritize. If the range is also the same, the vertical trend will be used to prioritize. XRX tracks this over time and can use the trend to determine that an aircraft above you and descending is a greater threat than one ascending.

This situation, the aircraft to our left is 500 ft. above us and descending, making it the primary threat. The other aircraft is climbing posing little or no threat. Situations like this commonly occur in heavy traffic environments, like airports, especially when doing pattern work.

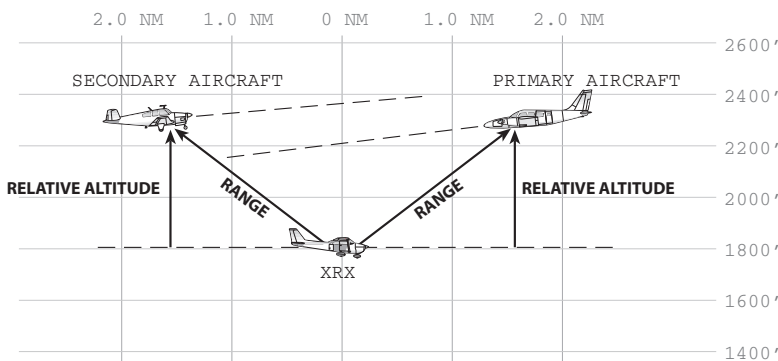

# Strengths and Limitations

## Strengths

### Ground RADAR and TCAS Network Coverage



XRX is a passive system, meaning it listens to replies from other aircraft. Other aircraft are responding to interrogations. There are two types of interrogation networks: Ground RADAR installations and TCAS- or other active system-equipped aircraft.

Ground RADAR installations provide ATC with aircraft data by interrogating outward from the sweeping antenna, pictured here. The range of each installation depends on the type of surrounding terrain and geography, but is usually 100-200 miles in diameter. Overhead, systems that interrogate, or active systems, exist which make up an even better network of interrogation. Examples of active systems are TCAS, Skywatch, and Ryan/Avidyne active systems. Because these systems are airborne, they are not limited by geographical features and provide an excellent platform for interrogation. A passive system which does not interrogate, such as MRX, only works if the interrogations are present. However, it is important to note that the combined effect of both overlapping networks provides for a nearly 100% coverage in the United States. The illustration below demonstrates this when the coverage of terminal, enroute and military RADAR is combined with TCAS interrogations from aircraft at any given moment. The same type of systems exist in countries abroad, especially the same airborne TCAS-based systems. The most important thing to remember is that interrogations happen virtually everywhere you may fly.



## Zero False Alerts

XRX boasts the unique ability to filter out any erroneous signals and only display verified transponder-equipped aircraft. Incoming signals must be completely decoded, the Mode A/C must correctly correspond to a valid altitude code, and XRX must be able to do this twice with the same aircraft. This process, among others, virtually guarantees that, if an aircraft information is being displayed, it can only be from a valid transponder-equipped aircraft.

## Limitations

### XRX Cannot Detect All Traffic



***Bearing indication is dependent upon adequate intruder transponder activity. In areas of reduced activity, bearing may appear to lag.***

XRX, along with all other collision avoidance technologies, cannot detect all aircraft. If another aircraft does not have a transponder, if the transponder is not turned on or to ALT, or in the rare case that no interrogation signal is present, there will be no reply for XRX to detect. While shadowing of signals can occur, XRX is programmed to correct for many instances. However some scenarios which can cause signal loss, or degradation, are:

- > **Target aircraft banking > 30° (top of aircraft visible, bottom turned away):** This can happen because the other aircraft's transponder antenna is on the bottom of the aircraft, however when the target aircraft is < 1.0 NM this is usually not a factor.
- > **On the ground, such as the run-up area Target aircraft approaching to land:** The range would be significantly further than actual. The reason is because as the other aircraft approaches, their transponder signal reflects off of the ground and phase cancellation becomes very prominent when they are < 500 feet above ground and coming towards you. When in the run-up, keep this in mind and consider the range to be 50% closer than what it shows. This is not a problem in the air, since XRX antenna reception is not competing with the ground and forward lobes of the target aircraft for signal reception.
- > **Directional ambiguity conflicts**



Because the primary method of tracking aircraft is based on altitude for GA aircraft squawking 1200, a split in ambiguity is possible when two aircraft are at the same altitude, but in different directions. The display may **briefly** display both opposite directions (see illustration) until a change in their altitudes allows XRX to split the two aircraft into different profiles.

### Realistic Detection Window



***In a metallic aircraft, range may be reduced by up to 60% in the area directly behind the aircraft ( $\pm 20^\circ$ ).***

A common metallic single-engine aircraft exhibits a detection window similar to the diagram here. In metallic aircraft, it is important to note that directly behind your aircraft is a natural airframe shadowing effect due to the vertical tail and empennage mass. However, this region is a very small portion of airspace.



□ Typical Detection Window (High Wing)

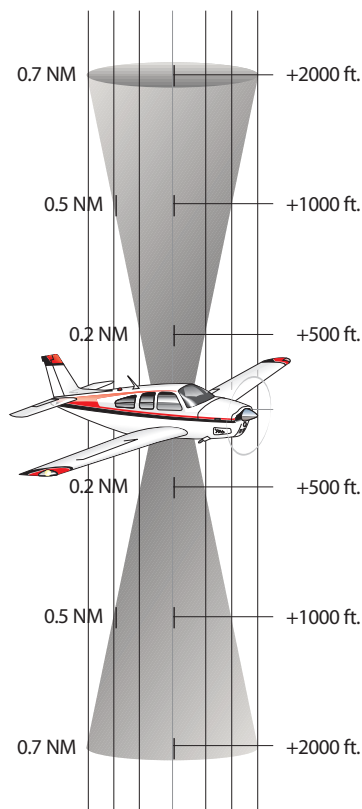

The true effect of this is a limitation in overall detection, not a reduction in bearing quality. An example of this effect is an aircraft at 3.0 NM would indicate 6.0 NM, or an aircraft at 0.5 NM would indicate 1.0 NM. It is a common misconception that multipath propagation that can occur when an RF signal takes different paths around this type of blockage when propagating from the source to the destination. This propagation has no effect on bearing quality, meaning that the tail section of your aircraft will not force an incorrect bearing from the target aircraft.

If your aircraft type is composite, you will not notice this anomaly.

### Cones of Confusion

At the point where the transmitting signal is either directly above or below your aircraft, cone-shaped areas exist above and below your aircraft in which the directional sensing ability becomes uncertain.

These cones, illustrated here, are similar in appearance and function to the cones of confusion that exist around VORs. These areas of ambiguity become larger the greater the vertical separation. An aircraft entering into these areas of ambiguity may momentarily show up as from more than one direction. In other words, more than one directional arrow may be displayed. As soon as the aircraft passes through, the new direction will be acquired and accurately displayed once again.

The less vertical separation exists between you and the target aircraft, the greater the accuracy of the bearing information. In other words, aircraft close to your altitude are easier to determine their bearing. Aircraft at a high angle to you approach the cone of confusion.

## North Turning Compass Error

XRX, like all other compasses, can experience a magnetic phenomenon known as turning errors under certain conditions. When a north-bound aircraft banks to turn, the compass momentarily turns in the opposite direction before “catching up” with the correct heading.

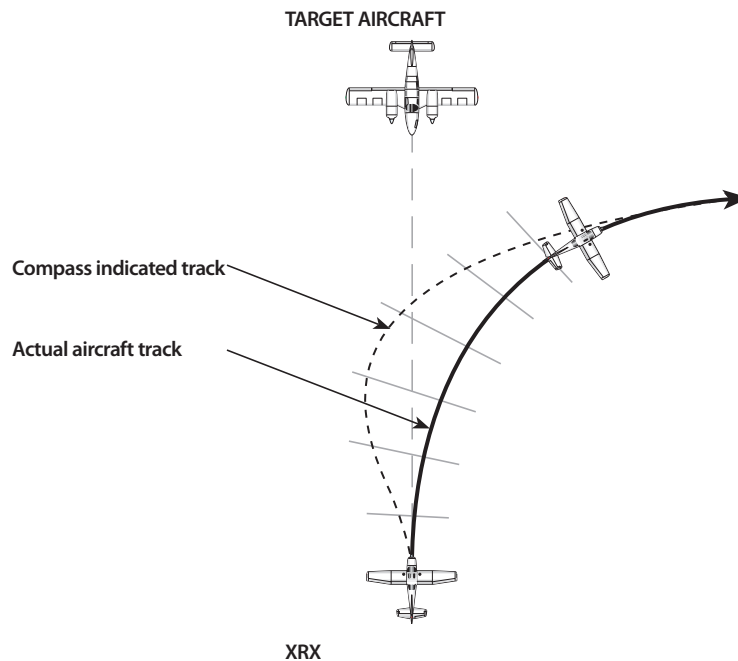

***When starting a turn off a northern heading and banking more than 15°, the compass may lag and momentarily show traffic in the opposite direction.***

Please consider these points when turning in an aircraft:

- > If on a northerly heading and a turn is made toward east or west, the initial indication of the compass lags or indicates a turn in the opposite direction. The lag diminishes as the turn progresses toward the east or west where there is no turning error. For example, when turning from a heading of 000 to 045, the heading indicator and any associated traffic may indicate a turn to the left (as much as 45°, heading 315 in the example) before “catching up” to heading 045.
- > If on a southerly heading and a turn is made toward east or west, the initial indication of the compass will indicate a greater amount of turn than is actually made. This lead also diminishes as the turn progresses toward east or west where there is no turn error. This error has little or no visible effect on XRX.
- > The amount of lead or lag is maximum on north / south headings and depends upon the angle of bank used and the latitude of the aircraft.
- > When on an east or west heading, no error is apparent while entering a turn to north or south.



## Visually Identifying Aircraft

Please be aware of what you can and can't visually identify. Many pilots will experience a situation where the unit will show an aircraft and attempts to visually identify it are unsuccessful. The following is a short list of visual impairments to consider:

- > Even to a well-trained eye, general aircraft beyond 1.5 to 2 miles away are too small to see
- > Visual effects, such as ground clutter, optical myopia, and haze can obscure aircraft
- > Only a relatively small "slice" of the 360° area around the cockpit is within the pilot's scan. Aircraft above, below, and behind may be blocked by your aircraft and much more difficult to see.
- > Aircraft at or about your same altitude tend to appear 200 feet lower for every half mile of distance between you and the aircraft. This is an optical illusion which is caused by the curvature of the earth (the horizon) combined with your aircraft angle of attack.

## Recognition & Reaction Time

Running time	Action	Seconds
00:00	See object	0.1
00:00	Recognize aircraft	1.0
00:01	Become aware of collision course	5.0
00:06	Decision to turn left or right	4.0
00:10	Muscular reaction	0.4
00:10	Aircraft lag time	2.0
<b>00:12</b>	<b>TOTAL TIME</b>	<b>12.5</b>

Table E: Recognition & Reaction Time

Range	Seconds to Impact	
	600 MPH*	360 MPH*
10 miles	60 secs.	100 secs.
6 miles	36 secs.	60 secs.
5 miles	30 secs.	50 secs.
4 miles	24 secs.	40 secs.
3 miles	18 secs.	30 secs.
2 miles	<b>12 secs.</b>	20 secs.
1 mile	<b>6 secs.</b>	<b>10 secs.</b>
0.5 mile	<b>3 secs.</b>	<b>5 secs.</b>

Table F: Time to Closest Approach Point (CAP)

\*Combined A/C speeds. **BOLD** times mark when insufficient time remains to alter course.

The importance of early warning cannot be stressed enough when it comes to detecting a potential threatening aircraft. These charts indicate how combined aircraft speed and distance play a role in determining your reaction time.

According to the FAA, a typical response time is 12.5 seconds. This translates to a one- to three-mile minimum response distance from an incoming aircraft. PCAS will help you increase awareness and response time.

The data presented is from FAA AC 90-48C.

# Buttons and Functions



1 > **Power**

Press once to turn unit on. Press again to turn unit off.

2 > **Mute**

Press to mute all audio output; press again to turn mute off and hear audio alerts. Once pressed, the unit will remain in mute until the button is pressed again. Mute will be indicated by replacing the volume bars with the word MUTE.

3 > **Menu / Select**

From the traffic screen, press to enter menu mode. Press again to advance through the menus and back to the traffic screen.

4 > **Up**

In traffic screen, turns volume of the headset voice alerts up and performs a system audio test on both the voice alerts and the tone generator.\*

In menu mode, moves selector up.

5 > **Down**

In traffic screen, turns volume of the headset voice alerts down and performs a system audio test on both the voice alerts and the tone generator.\*

In menu mode, moves selector down.

> **Administrative Mode**

To enter Admin mode, press and hold **mute [2]**, then press **down [5]**.

> **Backlight Adjustment**

To dim or brighten the backlight, press and release **mute [2]**. When the unit is in mute mode, press **up [4]** to brighten or **down [5]** to dim. Press and release once per "step". Do not hold down the **up** or **down** button.

\* The volume of the audible beep is fixed and does not change volume.

# Menus

## Hierarchy and Selecting

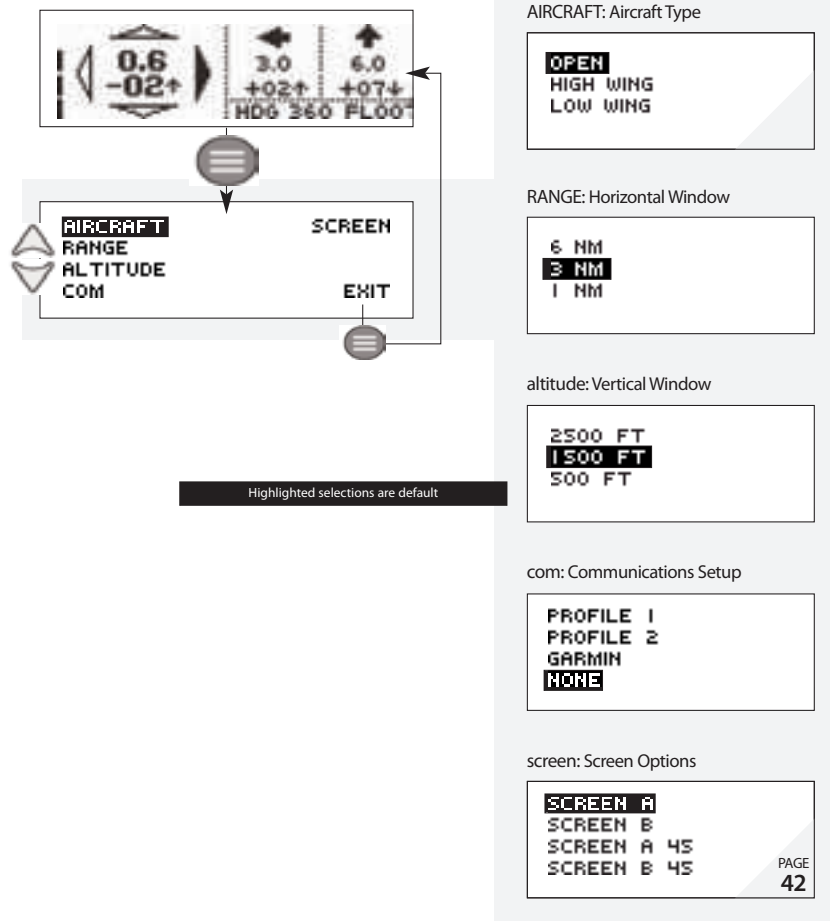

XRX uses simple menus to define the parameters for your flight. From the traffic screen, press the **menu/select** button, located to the right of the display, to advance through the menus, and back to the traffic display screen.

To select a highlighted menu parameter and change the setting, press the **up** and **down** buttons until the parameter is highlighted, then press the **menu/select** button to display the sub-menu.

In the sub-menu, use the **up** and **down** buttons to highlight the desired setting, then press **menu/select** to return to the main menu.

Your settings will be saved even after the unit is powered off.

Pressing the **Mute** button at the main menu acts as an escape key and will return to the traffic screen.

**Menu 1: Aircraft Type**

To increase accuracy, different airframe types have different characteristics that effect the antenna reception pattern.

- > **Open**  
No compensation for airframe, such as a composite aircraft
- > **High Wing**  
Antenna pattern compensation for a metal high-wing airframe
- > **Low Wing**  
Antenna pattern compensation for a metal low-wing airframe

To select an aircraft type:

- 1 > From the Traffic Display Screen, press the **menu/select** button once to access the menus.
- 2 > Press the **menu/select** button to select the Aircraft Type menu.
- 3 > Use the **up** and **down** buttons to select the desired type
- 4 > Press **menu/select** to return to the main menu.
- 5 > Press **mute** to return to the traffic screen.

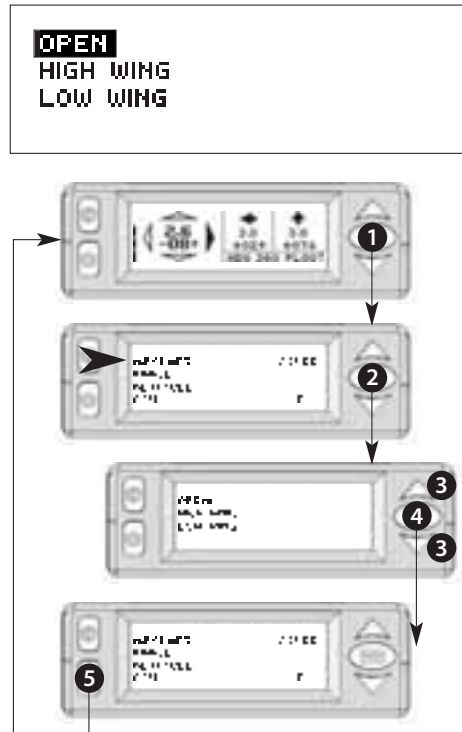

**Failure to select proper aircraft type can result in bearing errors.**

### Menu 2: Range

The range menu allows you to select the horizontal detection window, or range. The available range options are 6 NM radius, 3 NM radius, or 1.5 NM radius (shown as 1 NM in menu).

To select a Range window:

- 1 > From the Traffic Display Screen, press the **menu/select** button once to access the menus.
- 2 > Press the **down** button once to highlight "RANGE"
- 3 > Press the **menu/select** button to select the Range menu.
- 4 > Use the **up** and **down** buttons to select the desired range.
- 5 > Press **menu/select** to return to the main menu.
- 6 > Press **mute** to return to the traffic screen.

To return to the main menu, press **menu/select** instead of **mute** in step 5.

 Traffic outside the selected range window will not be indicated.

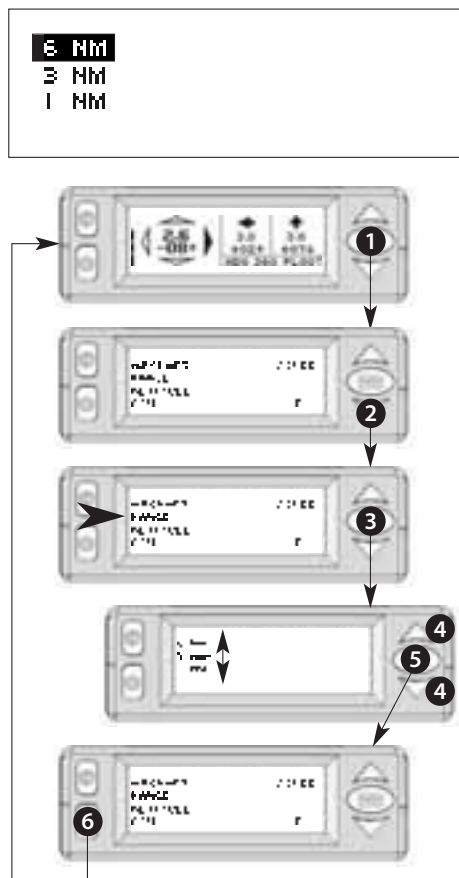

**Menu 3: Altitude**

The purpose of the altitude menu is to limit threat indications based on altitude separation from your aircraft, especially when operating in dense traffic environments.

To select an Altitude Limitation:

- 1 > From the Traffic Display Screen, press the **menu/select** button once to access the menus.
- 2 > Press the **down** button twice to highlight "ALTITUDE"
- 3 > Press the **menu/select** button to select the Altitude menu.
- 4 > Use the **up** and **down** buttons to select the desired altitude.
- 5 > Press **menu/select** to return to the main menu.
- 6 > Press **mute** to return to the traffic screen.

 Traffic outside the selected altitude window will not be indicated.

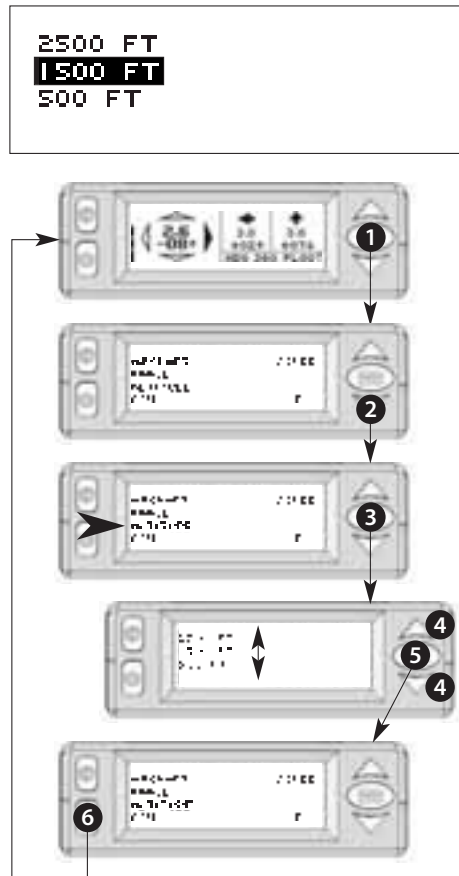

### Menu 4: Third-Party Communications Setup (Com)

XRX data can be displayed on external, third-party moving-map and EFIS systems through the RS-232 (DB9) port on the back of the unit. Use this menu to select the appropriate system you wish to connect.

To use a different communications setup:

- 1 > From the Traffic Display Screen, press the **menu/select** button once to access the menus.
- 2 > Press the **down** button three times to highlight "COM"
- 3 > Press the **menu/select** button to select the Com menu.
- 4 > Use the **up** and **down** buttons to select the com setting.
- 5 > Press **menu/select** to return to the main menu.
- 6 > Press **mute** to return to the traffic screen.



When a com selection other than "none" is made, the main traffic screen will be replaced with a static screen displaying the current com mode. No traffic data will be displayed on the XRX screen. Menu functions can still be accessed directly on the XRX by pressing the **menu/select** button.

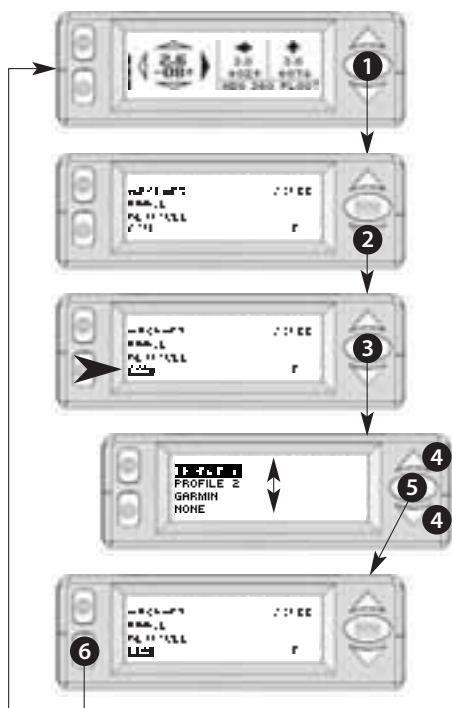
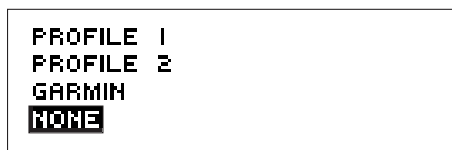

**Switches are factory set to work with all third party devices.**

XRX is capable of connecting to a wide array of third-party systems, including moving map and EFIS systems, including Garmin GPSMap 396/496, AnywhereMap, Blue Mountain Avionics, Grand Rapids Technologies. It is important to note that XRX is not certified by the FAA to provide traffic information to other certified systems.

Please refer to our third-party integration website for instructions specific to a particular device, at [www.zaon.aero/integration](http://www.zaon.aero/integration).

### Menu 5: Screen Options

The XR2 offers the unique ability to display data in different ways and at different angles.

To use a different screen option:

- 1 > From the Traffic Display Screen, press the **menu/select** button once to access the menus.
  - 2 > Press the **down** button four times to highlight "SCREEN"
  - 3 > Press the **menu/select** button to select the Screen menu.
  - 4 > Use the **up** and **down** buttons to select the desired screen type.
  - 5 > Press **menu/select** to return to the main menu.
  - 6 > Press **mute** to return to the traffic screen.
- > **Screen A:** This is the standard traffic screen layout. The primary aircraft is on the left, and two secondary aircraft are on the right, above the local altitude and heading.
- 1 > Primary aircraft
  - 2 > Secondary aircraft #1
  - 3 > Secondary aircraft #2
  - 4 > Local heading and altitude

- > **Screen B:** This layout presents you with an alternate overhead view of the top three aircraft with reference to bearing and range only. A range ring representing the maximum detection range surrounds a display of aircraft in relation to your aircraft.
- A > Primary aircraft
  - B > Overhead view, enclosed by range ring
  - C > Your aircraft
  - D > Target aircraft (maximum of 3)
  - E > Range setting

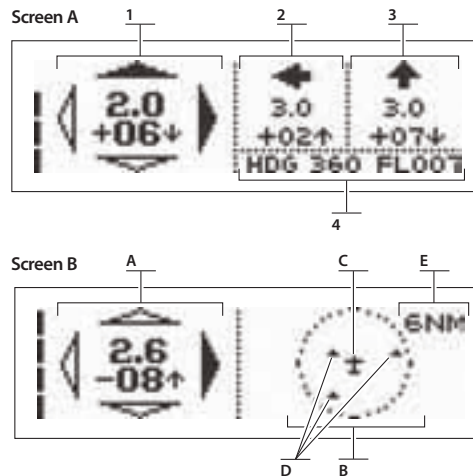
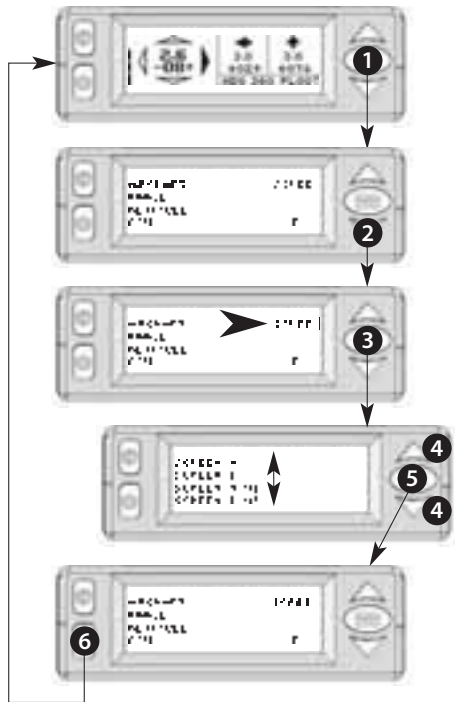
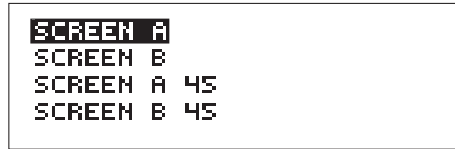

**The overhead view in Screen B does not contain altitude information. Screen B was intended for quick reference only.**



> **Screen A 45:** This setting will adjust the bearing and compass 45 degrees to the

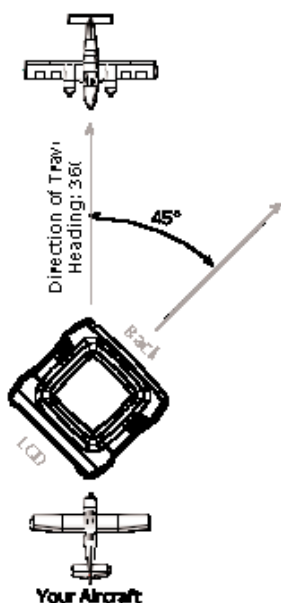

left so that XRX can be placed on the right side of the instrument panel and angled towards the pilot. If your glareshield is short, or standard unit placement directly in front of you is not possible or inconvenient, this setup will allow for an alternate placement.

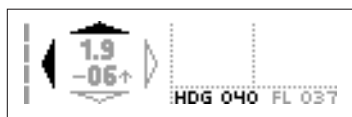

**Without the 45° correction**, the unit would display the aircraft in the example to the right incorrectly.



**With the 45° correction**, the unit allows the correct processing of the aircraft in relation to the aircraft.

If you calibrate the compass with the 45° correction turned on, you must still face XRX due north. Calibration will ignore the 45° correction.

> **Screen B 45:** This setting will perform the same angle correction as the above setting, but will display Screen B.

## Additional Menus: Administrative Mode

Your XRX unit comes fully calibrated and ready to use. If, however, any of the internal sensors start to drift, adjustments can be made using the admin menus. This menu provides access to compass and altimeter calibration screens, as well as a general information about the environment and the information the on-board sensors are tracking.

To enter Admin mode:

- 1 > Press and hold the **mute** button
- 2 > Press the **down** button within 3 seconds

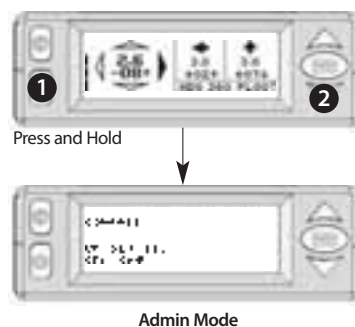

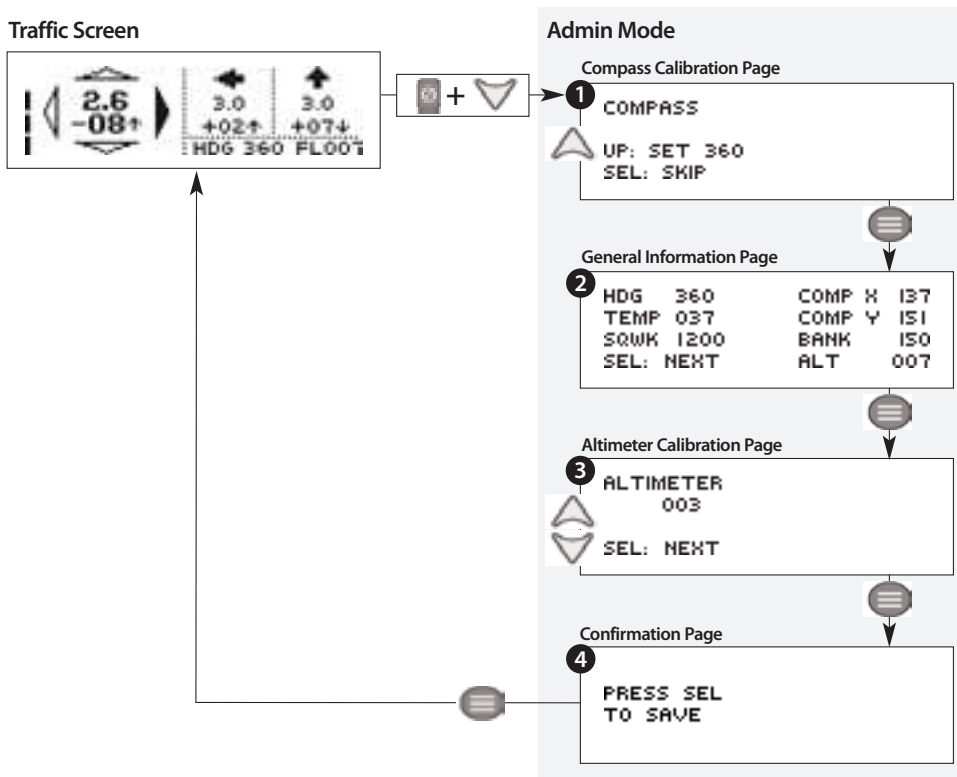
**Menu Hierarchy**

Once in Menu mode, navigate through a series of four pages. These pages allow for:

- 1 > Compass calibration
- 2 > The display of general information about the environment and the information the on-board sensors are tracking
- 3 > Altimeter calibration
- 4 > Confirmation of these changes.

**Page 1: Compass Calibration**



The first admin page allows for the recalibration of the internal compass.

The following actions can be performed on this page:

- A > Press the **menu/select** button to continue to the next page
- b > Recalibrate the compass using the procedure below

XRX contains a solid-state compass to provide the local heading and smooth traffic transitioning. The compass is factory calibrated and shouldn't need to be re-calibrated in most cases. If you notice the local heading is in error by more than 20°, you can recalibrate the compass using the following steps:

- 1 > Make sure XRX is level to the ground ( $\pm 10^\circ$ )
- 2 > Make sure XRX unit is facing directly north using your aircraft's magnetic compass (display faces south)
- 3 > Press and hold the **mute** button
- 4 > Press **down** button within 3 seconds to enter admin mode, then wait 30 seconds to allow the compass to stabilize.
- 5 > Press the **up** button. Wait for the compass to calibrate (the word "wait" will appear in the top right of the screen). When calibration is complete, the screen will advance to the next admin page.

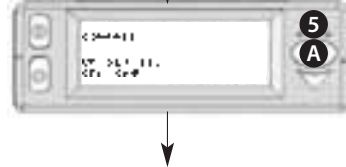
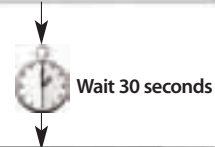
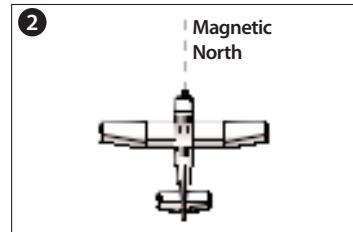
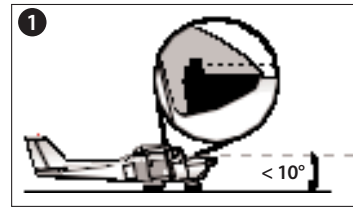

To skip compass calibration press the **menu/select** button [A] to move to the next admin page.



**Miscalibrating the compass will directly result in bearing errors of all traffic during turns.**

**Page 2: General Information**

HDG 360	COMP X 137
TEMP 037	COMP Y 151
SQWK 1200	BANK 150
SEL: NEXT	ALT 007

The next admin menu displays general information regarding both your XRX system and your aircraft.

The following actions can be performed on this page:

- A > Press the **menu/select** button to continue to the next page
- B > Press the **up** button to perform the system audio test

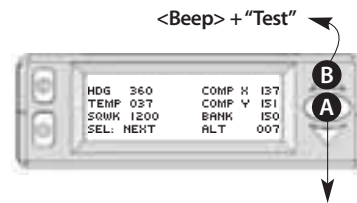

The following information is displayed:

- > Your current magnetic heading (HDG)
- > XRX system temperature in Celsius (TEMP)
- > Your aircraft squawk code (SQWK)
- > The local altitude (ALT)
- > Coded compass and bank/pitch angles

**System Audio Test**

Pressing the **up** button [B] on this page will perform a test on the audio system. **You will hear the In-Cabin beep, followed by the voice annunciation "Test" from the audio cable.** You may perform this step as many times as necessary to hear the test audio at louder or softer volumes. Your headset must be hooked up in order to hear the voice annunciation (see "Connecting the Audio" in the "Setup" chapter for more information on hooking up the audio).

This audio test can also be performed at the traffic screen by simply pressing the up or down arrows.

### Page 3: Altimeter Calibration



It is recommended that you check your altimeter every 6 months by comparing your aircraft altimeter's pressure altitude (tuned to 29.92) to the XRX pressure altitude shown in the right hand bottom of the traffic screen.

The following actions can be performed on this page:

- A > Press the **menu/select** button to continue to the next page
- B > Adjust the internal altimeter using the procedure below.

To adjust your altimeter:

- 1 > In your aircraft, enter 29.92 into the Kollsman window of your altimeter
- 2 > Press the **up** and **down** buttons to match your aircraft's altimeter pressure altitude of 29.92. The XRX displays altitude in 100 ft. increments, or flight levels. For example, 003 equals 300 feet.

Pressing **up** or **down** will change the altitude shown. However, when you switch from changing altitude down or up, the altitude will reset to the factory default setting. Simply continue from this point to press the **down** or **up** buttons until you achieve the desired altitude. To continue to the next screen, press the **menu/select** button [A].

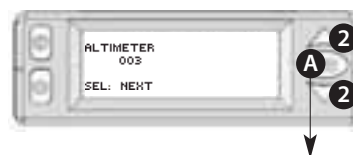
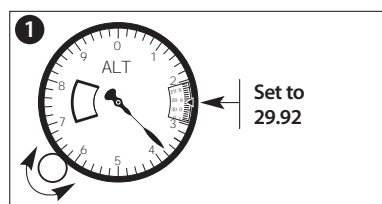

### Saving the Settings



The next admin page allows you to save to flash RAM the changes you have made in the admin pages and will remain even after turning off the unit.

Press the **menu/select** button [A] to return to the traffic screen.



# Frequently Asked Questions

## How does PCAS detect traffic?

PCAS is a passive, transponder-based detection system. Passive refers to the sensing method. Passive systems listen for replies from transponders to interrogations. In comparison, active systems send the interrogation to “spark” the replies from aircraft within the detection area. Passive systems are extremely effective in most areas because of the abundance of interrogations from other active systems. Ground-based RADAR and airborne TCAS systems are examples of active systems. PCAS is able to receive interrogation responses sparked by both of these methods. In fact, in an area of average coverage, PCAS rejects 50% or more of the incoming signals because of redundancy. Refer to page 16 (“How does XRX work?”) and page 31 (“Ground RADAR and TCAS Network Coverage”) for more on this.

## Are there any areas in which XRX will not detect traffic?

Possibly, however, coverage should be greater than 90% in the US. Because PCAS is a dual-environment system, it can detect replies to both ground RADAR and TCAS interrogations. Refer to the illustrations on page 31 (“Ground RADAR and TCAS Network Coverage”) for approximate coverage areas. Ground RADAR sites cover the majority of the US, but because of the altitude sensitivity of the RADAR interrogation, pockets do exist when a primary RADAR site is not close-by or is obstructed by hills or mountains. However, TCAS systems in aircraft (usually airliners flying at 30,000+ ft overhead) broadcast to 100 miles and are not limited by ground clutter obstructions. It is very common to be at an airport in which you must climb to 1000+ feet before ATC can detect you (through ground RADAR) but XRX will detect other aircraft around you because of an airliner flying overhead with TCAS.

## Will XRX work if I don't have a transponder?

Yes. A local transponder is usually used to determine the local altitude, since information given is relative to your altitude. However, because XRX incorporates a built-in altimeter as a backup source for local altitude, a local transponder is not required. This is useful for use in gliders, hot air balloons, or ultralights that are usually not transponder equipped. Regardless of a local transponder, XRX will always be able to determine the local altitude, ensuring accurate traffic information.

## Will XRX detect another aircraft that does not have a transponder?

No. As with all collision avoidance systems, the target aircraft must have a functioning transponder. Without a transponder, there is no signal to detect.

## Why does XRX need an internal altimeter?

Because the altitude information is relative to your altitude, the unit must know your local altitude at all times. One of the features that makes PCAS superior is the patent-pending built-in altimeter, which establishes an accurate base reference for the relative altitude.

Portable collision avoidance avionics which display altitude information must rely on a secondary source for altitude rather than the host transponder only. Competitive units which do not incorporate an altimeter will

experience the following problems.

For an in-depth explanation of this, see page 18 (“Built-in Altimeter for Relative Altitude”).

#### **Why does XRX need an internal compass?**

The built-in compass allows for smoothing of the traffic direction shown. Since aircraft transponders do not broadcast a constant flow of information, but rather send only when interrogated, a compass is used to track the local movements and relate them to any traffic currently being displayed on the screen. The compass also corrects for sampling averaging errors when turning. See page 17 (“Built-in Compass for Relative Bearing”) for more information.

#### **How does PCAS compare to TIS?**

TIS, or Traffic Information Service, refers to the broadcast and receiving of traffic information from Ground-Based Transmitters (GBTs) via a transmitted RF signal. Contained in this signal is the information ATC uses to display traffic within the service area. TIS offers some advantages, but a few disadvantages when comparing to the way PCAS delivers traffic information.

- > TIS offers a fairly comprehensive view of traffic, usually displayed onto a moving map. However, TIS information is limited to the service area, or area in which GBTs are equipped to send a TIS signal. As of this printing, less than 50 TIS stations exist in the US. In addition, the Mode S TIS broadcast is being scaled down in preparation for a new datalink, ADS-B. Once outside the service area, traffic is unavailable. PCAS, on the other hand, is not tied to a ground-based service. Traffic displayed on the PCAS screen is detected and computed independently of a ground-based service. In fact, the only thing PCAS needs to function is a Mode C transponder in the other aircraft (which all other collision avoidance systems need as well), which makes PCAS truly a peer-to-peer system.
- > TIS requires a Mode S transponder and a way to visually display the traffic information, usually on an MFD. While the end result is clear and concise, the cost of such systems and installation can be expensive for general aviation. PCAS is completely self-contained and does not require any additional hardware to function. It's portable as well, meaning that it can be taken from aircraft to aircraft, or removed for security.
- > PCAS can derive its information from both ground-based interrogations as well as TCAS-equipped aircraft flying overhead. Considering the ground clutter limitations of RADAR, PCAS often gets more information from TCAS interrogations than ground RADAR, especially when flying low to the ground. TIS is a ground-RADAR-based only, and aircraft flying below the RADAR horizon will not be detected.
- > PCAS information is updated as soon as the target transponder sends information, which is usually several times per RADAR sweep or TCAS interrogation. TIS information must be processed through several ground systems, rebroadcast, received and displayed. Traffic information, particularly altitude information, can have considerable delays.
- > One other consideration is range calculation. PCAS displays slant range, or true distance, in estimated miles. TIS displays range from an overhead-view perspective. For example, if the target aircraft is 2500 feet directly above you, the closest PCAS will show the traffic is 0.5 NM. TIS would show the traffic on top of your position in a 2-D fashion. However, TIS range calculations are time-based, which can be more accurate at distance. The relative altitude would be indicated the same on TIS as with PCAS.

#### **Is the audio beeping loud enough to be heard over a headset in the cockpit?**

XRX incorporates an internal audible tone generator (3.2 KHz) which beeps to advise the pilot and passengers of a traffic alert or advisory. This tone is high-pitched and at a volume that can be heard over the noise level in a standard cockpit, similar to the stall warning horn or the outer marker tone. Because noise-cancelling headsets

generally reduce noise at a much lower frequency (approximately 400 Hz and below), they have little effect on restricting the volume of the tone generator, which can be heard clearly through ANR headsets. The tone is a short double beat for advisories, or a triple-beat for alerts. The tone is only heard once when the advisory or alert is first announced.

#### **Does PCAS interface with other systems (such as moving maps or MFDs)?**

PCAS XRX uses an RS-232 protocol to export the traffic information. Many third-party moving map and EFIS systems, including those from Garmin, Blue Mountain Avionics, Grand Rapids Technologies, AnywhereMap, AirNav, and many more. The data is available to any system with the ability to interface through RS-232 and read the data. For up-to-date and model-specific information, visit our third-party integration website at [www.zaon.aero/integration](http://www.zaon.aero/integration).

When interfaced with an external system, XRX provides a com menu for selecting the proper protocol for that system. When an external system is being used, the traffic screen is blanked to allow for greater data processing. Buttons function normally during this time. See page 42 ("Menu 4: Third-Party Communications Setup") for more information.

#### **How well does the unit perform in a high-temperature environment?**

Even though PCAS was designed to sit atop the glareshield, it should function normally in high-temperature environments, such as summer conditions. Several design elements assist with keeping PCAS within its operating temperature range. The grey color of the housing deflects much of the heat from direct sunlight. An internal cooling fan exhausts much of the heat build-up through the "gills" in the top of the unit. You may have noticed a slight whirring sound upon startup, which is from the fan. Electronic components were selected specifically for high heat tolerances. As with any electronics, heat can adversely affect performance. However, PCAS has been successfully tested to function normally at the top end of the 150°F (65°C) temperature range.

#### **Can XRX be powered by anything other than the cigarette-lighter adapter?**

Yes. XRX can accept power from any DC source that outputs 10 to 40 V. External battery packs are available to power XRX for up to 22 hours. See our website for more information on XRX accessories. Also, XRX can be powered from a hard-wired power source, such as that from the avionics bus. If hard-wiring, make sure the plug is a 2.35mm barrel type, tip positive, providing between 10 and 40 VDC from a fused source, and that all FAA requirements are observed.

#### **Do I have to use the audio connections?**

No. XRX will function normally without any audio hookups. The audio hookup simply enables an advisory or alert to be heard through the headset. When XRX determines that a detected aircraft may be close enough to warrant an alert or advisory, an attempt is made to alert the pilot to this impending threat. XRX incorporates two audio systems in order to accomplish this: a headset-direct female voice through a simple headset connection, and a high-pitched tone generator. The voice alert and the tone generator can be used or turned off in any combination. Also, an instant-mute function is available to suppress any audio output.

#### **How does XRX know my bearing, altitude and squawk?**

The local bearing, or heading information displayed on the traffic screen, comes from the built-in compass. It is displayed in 10° increments. The local altitude comes from either the built-in altimeter or from your transponder



encoder, if one is present, broadcasting, and within tolerance. The altitude from your transponder is always double-checked against the built-in pressure altimeter to ensure accuracy. If any discrepancies occur, the unit defaults to using the built-in altimeter. The local squawk code comes from your transponder's encoder output, if XRX has successfully linked to your transponder. Otherwise, a code of "0000" is shown. The squawk code can be found on the General Information page in Admin mode (see page 43, "Additional Menus: Administrative Mode" for more information).

**Is there any other place to position XRX than on the glareshield?**

XRX must be in plain sight of other aircraft and has been specifically designed and calibrated for use atop the glareshield. Generally speaking, XRX must be used in this location. However, other mounting options such as suction-cup platforms may be used. XRX cannot be used in any area outside of this general area, however, such as on a seat or console, or mounted on the yoke. The directional antenna must be above the metal mass of the instrument panel, firewall and engine block with as clear of a view as possible, and must be oriented in a forward-facing manner (or 45° right when used in conjunction with the 45° screen option, see page 43). Options are or may soon be available for installing XRX into the panel with significant reconfiguration of the hardware. Visit our website for more information.

**Why can't I scroll through more than three aircraft at a time?**

XRX was designed to show up to three targets at a time, with the top priority, or primary aircraft, displayed on the left side of the screen. Additional aircraft are tracked, but are not as much of a potential threat than the three aircraft displayed. The primary aircraft represents the greatest threat to you. If this information was replaced, even temporarily, by a lesser threat, the greater threat may be overlooked. This would put the pilot at risk. XRX smartly manages traffic prioritizing so that the pilot doesn't have to.

# Troubleshooting

## Power

### Should the XRX unit be turned off when starting up the aircraft?

When using aircraft power it is always a good idea to keep any avionics off during startup. Since the aircraft has only two sources of power, the battery and the alternator, engine starting causes the battery to contribute considerable amperage to the starter which reduces its output voltage below that of acceptable levels for most avionics. While older, tube-style avionics are not as affected, newer processor-based avionics, such as XRX, may not deal well with this situation, even though most avionics devices turned on during this time period should simply reset itself. A potential power surge does pose some risk, however this is not very likely since the output voltage on most alternators are protected from such.

### Occasionally, when the power button is pushed, the unit turns off as soon as the button is released.

This system is turned on through a momentary press of the power button for less than one second. If the power button is held down for too long, the system will shut off when pressure is released. Press the power button for no more than one second, then release.

### Unit powers on, the display briefly illuminates, then unit immediately shuts off.

Check all connections for proper installation. Unit will shut off automatically if a short in the system is detected. Unplug all audio connectors and turn on unit. Check to make sure the minimum voltage and current are available through your power connector, both at the aircraft and at the tip of the power adapter (see Appendices: Specifications). If unit never starts up, unit needs to be repaired.

### Upon powering up, unit displays a garbled or semi-garbled screen, resets, then operates normally.

This is normal and simply means unit was reset (powered off then back on) too quickly. The unit will sense the improper startup and reset itself.

## Traffic Detection

### When tracking an aircraft flying overhead, ATC said traffic was less than a mile, but XRX showed the traffic was 2.0 NM. Why the difference in range?

XRX gives range based on true distance in three-dimensional space and is based off of received signal amplitude. Some aircraft such as airliners have twice the power output of most general aviation aircraft and will appear closer than in reality.

**Unit never detects traffic.**

If your XRX unit never displays traffic and you suspect or can visually identify aircraft around you, your unit may need to be serviced.

**A Note About ATC Services**

While ATC can provide invaluable services to you as a pilot, using them to verify aircraft displayed on the XRX screen may be unreliable. Remember, XRX is an airborne, dual network system capable of detecting aircraft responding to TCAS interrogations, or aircraft that are out of reach of Ground RADAR. A rule of thumb is, if the XRX is displaying traffic, the traffic must exist somewhere. Nothing else can generate the unique squawk and altitude codes used in sensing traffic.

**On the ground, during taxiing, or in the run-up, the unit starts showing traffic at erroneous altitudes.**

If you pass in close proximity to another aircraft either on the ground or when they are landing or taking off, XRX may momentarily receive their transponder altitude and think it is YOUR altitude. If this nearby transponder confusion occurs, the unit may display traffic below ground altitude or other traffic landing as too low or too high. This situation is self resolved as soon as your transponder transmits again, however it may be confusing until this occurs. To determine if another aircraft has set your altitude with their transponder, you would notice that the local altitude displayed is obviously higher than your ground level pressure altitude, and/or the squawk code may not agree with what your transponder is set to. Reset your XRX by turning it off, waiting at least two (2) seconds, then turning the unit on.

**When tracking an approaching target, the range appears to decrease rapidly as if it is “catching up”.**

When transponder antennas are coated with oil, dirt or other materials, the transmission properties can change. We encourage all pilots to make sure their transponder antennas get cleaned as often as possible to reduce this affect of antenna-forward attenuation. This attenuation will cause a distortion in the ability to accurately detect traffic. XRX will be forced to accommodate for this attenuation by updating the range information when it can get a clear signal.

**The unit constantly displays < 0.4 NM and “ALT +00”.**

Instead of ignoring your transponder, the unit is picking up your transponder as a threat. Try the following:

- > Make sure your transponder antenna is clean. Even a small amount of grease or dirt build-up can dampen your transponder signal.
- > Call Zoon and we can walk you through changing the local host transponder suppression level. This will allow XRX to “dig” a little deeper to lock onto your transponder. If this solution is not effective, you may need to contact a local avionics shop to test the power output of your transponder. The peak power output should be between 100 and 250 watts. Anything less is not acceptable under TSO tolerance, which is what XRX is calibrated to, and may not work with the XRX system.



Clean your transponder antenna often.

**Displays constant traffic DETECTION; unit constantly displays > 0.9 NM.**

Any traffic displayed can only be from another transponder-equipped aircraft. The only source for traffic detection is from other valid aircraft (unless the unit is detecting your own transponder, see above). In order for traffic to be displayed, XRX must decode a valid Mode C (altitude) signal code. Interference from your aircraft or avionics cannot create this code, and the pilot should trust this indication. It is not uncommon to see a consistent display of traffic within the detection window, especially when it is set to 6.0 NM as this is a large portion of airspace.

**Common responses to constant traffic detection:**

"I called ATC they said no traffic exists." This is an unreliable way of checking for traffic. ATC doesn't typically indicate traffic which is not a factor. This means there may still be traffic around you which XRX will detect. In addition, ATC may not necessarily be looking at a screen which shows all non-factor traffic. For example, some controllers use a "1200 filter" which blocks all VFR traffic squawking 1200 from being shown.

"I don't see any traffic and it says X.X NM" Traffic is typically not visible beyond 1.5 to 2.0 NM. Just because traffic can't be seen does NOT mean there is no traffic. First-time users may be surprised just how much traffic is nearby that was previously undetected. Again, XRX cannot display traffic unless a valid Mode C transponder code is detected.

"There can't possibly be someone at 5.0 NM for 10 minutes." Actually, this is very common. 5.0 NM may also indicate traffic is GREATER than 5.0 NM. Does the unit show multiple aircraft? If so, several aircraft are within the 5-7 mile range. The only way for XRX to display traffic is to receive a valid code from another transponder.

These responses are typical for many pilots because they simply cannot SEE the traffic they assume it is not real. Pilots must learn to trust the instrument, similar to trusting flight instruments during instrument flying.

**The local altitude displayed is different from my altimeter.**

XRX displays pressure altitude, not indicated altitude. It is using the same format as your transponder. Indicated altitude will only match when your barometric pressure is 29.92". To test this, set your altimeter to 29.92. It should agree with your XRX within  $\pm 100$  ft.

**While flying, the local altitude displayed is significantly different from the current pressure altitude.**

Check to ensure the pressure altitude was incorrectly computed. Check if the pressure has not changed since the calculation. If problem persists, the unit may need to be recalibrated. See page 48, "Altimeter Calibration".

**Sometimes range information skips, for example, from 5.0 NM to 3.0 NM.**

The transponder system on the target aircraft is not always transmitting; therefore this indicates the aircraft moved through 4.0 NM without transmitting for XRX to range it. Also, as an aircraft changes positions, antenna transmission lobes change, leading to signal alterations. This is normal.

**When viewing an aircraft on takeoff, the unit did not detect the aircraft until it was airborne or at a certain altitude.**

The aircraft was probably below RADAR coverage. Typically, once an aircraft has obtained an altitude of 300-500 feet AGL, it will be in coverage and start transmitting. Also, many pilots initially forget to switch their transponders to altitude. XRX, as with any other collision avoidance system, will not be able to detect an aircraft unless the target transponder is in altitude mode.

**When the target aircraft taking off or landing, the unit shows -100 or -200 feet which is not possible.**

This is caused by the additive effect of the tolerances involved with the systems. A transponder system has a tolerance of  $\pm 100$  feet. With two transponders involved (yours and theirs), as much as a  $\pm 200$  foot variance may occur. These tolerances are FAA specified, and this situation applies for even the most complex TCAS systems.

**The unit is alerting me and the aircraft is still 1.5 miles away.**

Change modes to decrease threat levels and narrow the scope of what your unit will consider a threat.

**The unit did not display any traffic or alerts when an aircraft flew by me.**

XRX does not detect ALL aircraft. For example, if the target aircraft is out of RADAR range, does not have transponder on, or the antenna signal is shadowed, among other scenarios, XRX may not be able to display the traffic. Also, check that the altitude mode did not limit the detection window below the target aircraft's position. For example, if an aircraft passed 600 feet below, and the altitude window was set at 500 feet, no traffic would be displayed.

**The range of some commercial airliners is displayed as closer than actual distance.**

Airliners typically use a higher power transmitter which can affect ranging. While this difference is slight, it can be noticed at greater ranges where the power-to-distance envelope widens. For example, traffic at a true distance of 6 to 10 nm may be displayed as 4 to 6 nm. The closer the traffic is, the more this situation is cleared up. For example, traffic at 1 nm may be displayed as 0.8. This difference should be completely unnoticeable.

# Appendices

## Appendix A: Specifications

### Environmental

Altitude	Min. 0 ft.	Max. 22,000 ft (FL220)
Temperature	Min. 0°C (+32°F)	Max. +65°C (+150°F)
Pressure	Min. 0 kPA (0 PSI)	Max. 100 kPA (14.5 PSI)
Humidity	Tested to 100% humidity	

### Mechanical

Dimensions	3.9 (100 mm)	Width
	3.6 (93 mm)	Depth
	2.7 (69 mm)	Height (includes antenna)
Weight	8.2 oz. (232.5 g)	

### Electrical

Power	10-48 VDC	Negative ground
Consumption	@ 14V	4.2 watts max.
	@ 24V	2.6 watts max.
Current	450-500 mA	475 mA nominal
Connector Type	2.35mm mini	Tip positive

### Receiver

Type	Superheterodyne / PLL x4	
Selectivity	1090 MHz	
Bandwidth	±8.1 MHz	
Signal Modes	X, Y, A, C, S, 2, 3/a, 3/c	
Scan Rate	3.2 kHz	
Data Rate	1000 kbps	
MTL Sensitivity	-78 dBm	
Max Peak Power	+28 dBm	
Max. Detection Range	22.0 NM	100% Error Rate
	7.0 NM	10% Error Rate
Receiver Dynamic Range	68 db	

### Accuracy

Range Resolution	0-2.0 NM	±0.1 NM
	2.0-3.0 NM	±0.2 NM
	3.0-6.0 NM	±1.0 NM
Bearing Resolution	30° (45° displayed)	
Altimeter Accuracy	±200 ft.	
Compass Accuracy	±20°	
Bank/Pitch Accuracy	±6°	
Temperature Sense	0.1°C	

## Antenna Array

Type	Directional capable, internal, multi-element directional array
Number of Antennas	4
Open Space	±8.2°
Obstruction	±30°
Sense	Amplitude / Phase
Phase Balance	±12°
Amplitude Balance	±0.5 dB
Phi Range	>65°
Polarization	Cross
Gain	+2.2 dBi

## Display

Type	FSTN Liquid Crystal Display, Black/White, Wide Temp
Resolution	122 x 32
Viewing Angle	12:00
Backlight	Blue-White Electroeluminescence

## Audio

Impedance	300 ohms x 2 channels or 600 ohms x 1 channel, selectable
Power	4.0 watts max. @ 2.5 volts peak-to-peak
Compatibility	Stereo / Mono selectable, ground isolation or connection

## Storage

Temperature	Min: -40°C (-40°F)	Max: +85°C (185°F)
-------------	--------------------	--------------------

## Accessories

A complete line of accessories is available from your local avionics or pilot supply store, or through Zaon direct.

## Appendix B: Configuration Switches

Your XRX unit has two groups of configuration switches, located inside the hatch on the bottom rear of the unit. Group A configures the audio and pressurization options, and Group B configures the RS-232 output options. To open the hatch, **remove the retainer screw** using a small Phillips screwdriver.

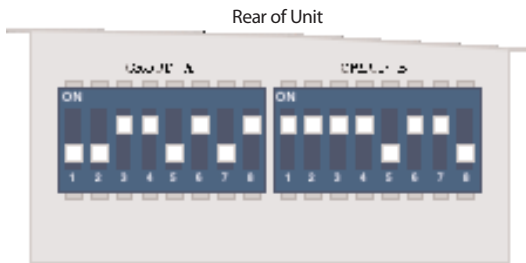

Inside Switch Compartment (default settings)



A	ON	OFF
1	300 Ω Impedance	<b>600 Ω Impedance</b>
2	Mono*	<b>Stereo**</b>
3	<b>Stereo**</b>	Mono*
4	<b>Ground Connect</b>	Ground Isolation
5	Pressurized	<b>Non-pressurized</b>
6	<b>In-Cabin Audio ON</b>	In-Cabin Audio OFF
7	Calibration Mode ON	<b>Calibration Mode OFF</b>
8	<b>+5 VDC to RS-232 Pin 9</b>	OFF / NC

B	ON	OFF
1	<b>RS-232 Enable</b>	RS-232 Disable
2	<b>DCD to DSR</b>	OFF / Disconnect
3	<b>RTS to CTS</b>	OFF / Disconnect
4	<b>DTR to DSR</b>	OFF / Disconnect
5	XRX TX to RS-232 RX	<b>OFF / NC</b>
6	<b>XRX RX to RS-232 TX</b>	OFF / NC
7	<b>XRX RX to RS-232 RX</b>	OFF / NC
8	XRX RX to RS-232 RX	<b>OFF / NC</b>

**Bold** items are factory default settings.

\* and \*\* selections are mutually exclusive. For example, to set to Mono (\*), A2 must be ON and A3 must be OFF.

Table G: Configuration Switch Definitions



## Appendix C: Customer Service

Before contacting your place of purchase for a repair or refund, call us directly. In most cases, any concerns can be satisfactorily remedied by one of our technicians or support staff.

### Online Support

Web Address	Description
<b>Register Your Unit</b> <a href="http://www.zaon.aero/register">www.zaon.aero/register</a>	<b>Please register your unit with Zaon Flight Systems.</b> This will keep you up-to-date with changes or revisions. Also, no repairs or warranty work will be performed on unregistered units.
<b>Avionics Web Site</b> <a href="http://www.zaon.aero">www.zaon.aero</a>	All information on Zaon avionics can be accessed from our avionics home page. Start here for most of your questions or information needs.
<b>KnowledgeBase</b> <a href="http://www.zaon.aero/support">www.zaon.aero/support</a>	An extensive database of articles has been established on the internet to assist with a variety of questions and concerns, from installation and operation to detection concerns and expectations. Before contacting us personally, we urge to you search the database for answers to many of your questions.
<b>Firmware Updates</b> <a href="http://www.zaon.aero/firmware">www.zaon.aero/firmware</a>	This site contains all information concerning the latest firmware releases for all of our products, including information on how to obtain a firmware update.
<b>Accessories</b> <a href="http://www.zaon.aero/accessories">www.zaon.aero/accessories</a>	Should you need to order or replace any avionics accessories, please visit the XRX accessories page. This page keeps you current with the latest accessories for your XRX.

### Personal Support

For personal support or technical questions, please call Zaon Monday through Friday, 8 am to 5 pm Central, at:

- > Toll-Free **(800) 496-9430**
- > International **+1 (469) 916-6640**
- > Fax **(469) 916-9939**
- > Email **support@zaon.aero**
- > Visit **www.zaon.aero**

## Appendix D: Firmware

**Current Version: 2.0** (As of 9/2007. Refer to the Firmware Updates website for the most up-to-date information)

### Upgrading the Firmware

Your XRX unit can be reprogrammed to accept future firmware updates.



Startup screen, showing firmware version installed

The current firmware number will be displayed during the startup sequence (i.e. 1.0). For the latest firmware version, or for instructions on how to get your firmware updated, please visit the Zaon website at [www.zaon.aero/firmware](http://www.zaon.aero/firmware).

Firmware updating may require you to send in your unit to the factory for reprogramming and recalibrating.

### Firmware Change History

#### Version 2.0

- > Garmin integration added to COM menu
- > Startup screen automatically times out to traffic page after 35 seconds
- > Minor detection tuning changes

#### Version 1.9

- > Minor performance tuning changes

#### Version 1.8

- > In addition to audible advisory and alert, screen now flashes (reverses) for visual cue

#### Version 1.7

- > Third-party "COM" menu changed to more generic labels (ANYWHERE MAP became PROFILE 1, TRUE FLIGHT became PROFILE 2)

#### Version 1.6

- > Minor calibration tuning changes

#### Version 1.5

- > Minor calibration tuning changes

#### Version 1.3

- > Minor degarbling, filtering, and performance tuning changes

#### Version 1.2

- > Added automatic save feature for Aircraft Type, Range, Altitude, and Screen Style settings, even if the unit is powered down
- > Changed and enlarged display fonts for better clarity and readability of traffic
- > Added option to select Ground Mode or Flight Mode in Warning Screen following startup
- > Added "test" message feature when audio volume is changed up or down
- > Improved bearing algorithms in 45 to 90 degree sectors in each quadrant
- > Adjusted range values in 2.0 to 6.0 NM fields
- > Fixed erroneous "500 FT1" in ALTITUDE menu
- > Adjusted profile tracking in reduced-range historical track
- > Revised adaptive filtering to allow faster lock time on traffic in reduced radar coverage
- > Corrected audio issue where maximum volume overloads system

#### Version 1.1

- > Revised climb/descent time allotment in profile tracking
- > Revised pressure altitude/thermal auto adjustment
- > Changed compass N/S split algorithm
- > Revised maximum range trigger level
- > Revised minimum range thresholds
- > Decreased host transponder threshold defaults
- > Revised coast mode from 28 seconds to 32

Initial Release: Version 1.0 (12/2005)

## Appendix E: Warranty Information

### Three-Year Limited Warranty

Zaon Flight Systems, Inc. ("Zaon") warrants PCAS Model XRX ("Product") (including any standard, included accessories) with the following conditions:

**WHAT THIS WARRANTY COVERS:** This warranty covers all defects in material or workmanship with the following definitions. **LABOR:** For a period of 36 months from the date of purchase, if this Product is determined to be defective, Zaon will repair or replace the Product, at its option, at no charge. **PARTS:** In addition, Zaon will supply, at no charge, new or rebuilt replacements in exchange for defective parts for a period of 36 months.

**WHAT THIS WARRANTY DOES NOT COVER:** This warranty does not cover customer instruction, installation, set up adjustments or signal reception problems caused by anything other than internal component malfunctions as specified above. This warranty does not cover cosmetic damage or damage due to acts of God, accident, theft, misuse, abuse, negligence, commercial use, or modification of, or to any part of the Product, including the antenna. This warranty does not cover damage due to improper operation or maintenance, connection to improper voltage supply, or attempted repair by anyone other than an authorized Zaon facility. This warranty does not cover Products sold AS IS or WITH ALL FAULTS, or consumables (such as batteries). This warranty is valid only in the United States. REPAIR OR REPLACEMENT AS PROVIDED UNDER THIS WARRANTY IS THE EXCLUSIVE REMEDY OF THE CONSUMER. ZAON SHALL NOT BE LIABLE FOR ANY INCIDENTAL OR CONSEQUENTIAL DAMAGES FOR BREACH OF ANY EXPRESS OR IMPLIED WARRANTY ON THIS PRODUCT. EXCEPT TO THE EXTENT PROHIBITED BY APPLICABLE LAW, ANY IMPLIED WARRANTY OF MERCHANTABILITY OR FITNESS FOR A PARTICULAR PURPOSE ON THIS PRODUCT IS LIMITED IN DURATION TO THE DURATION OF THIS WARRANTY. In no case will Zaon be held liable for direct, or incidental damages resulting from any defect or omission in the Owner's Manual or other related items and processes, including, but not limited to service, loss of business, anticipated profit, or other consequential damages. This warranty is invalid if the factory applied serial number or original case seals have been altered or removed from the Product. Some states do not allow the exclusion or limitation of incidental or consequential damages, or allow limitations on how long an implied warranty lasts, so the above limitations or exclusions may not apply to you. In addition, if you enter into a service contract with Zaon within 36 months of the date of sale, the limitation on how long an implied warranty lasts does not apply to you. This warranty gives you specific legal rights, and you may have other rights which vary from state to state. The remedies herein shall be cumulative and additional to any other or further remedies provided in law or equity.

ZAON MAKES NO WARRANTIES, EXPRESS, STATUTORY, IMPLIED OR OTHERWISE, OTHER THAN AS EXPRESSLY SET FORTH HEREIN. ZAON EXPRESSLY DISCLAIMS THE IMPLIED WARRANTIES AND CONDITIONS OF NON-INFRINGEMENT, MERCHANTABILITY AND FITNESS FOR A PARTICULAR PURPOSE, TO THE MAXIMUM EXTENT PERMITTED BY LAW.

**Opening your avionics unit voids this Warranty.** There are no user-serviceable parts inside your XRX unit. Opening the unit will change the individually-tuned internal circuitry and WILL VOID YOUR WARRANTY COVERAGE.

### To Return Your Unit For Repair

If you purchased XRX from a Zaon dealer, do not contact the dealer for repair. All repairs must be completed through Zaon directly. To return your XRX for repair, call us to receive a Returned Merchandise Authorization (RMA) number, return questionnaire and shipping instructions. **No repairs or refund will be made without an RMA number.**

### To Return Your Unit For A Refund

Units must be returned through the place of purchase. Shipping costs for all returns hereunder shall be at buyer's

expense.

### Register Your Unit

**Please register your unit with Zaon Flight Systems.** This activate your product warranty and will keep you up-to-date with changes or revisions. No repairs or warranty work will be performed on unregistered units.

If the original registration card is missing from your unit, register online at [www.zaon.aero/register](http://www.zaon.aero/register) or use the card below. Either cut out or photocopy this page and mail the completed card to:

**Zaon Flight Systems, Inc.**  
**15946 Midway Road**  
**Addison, TX 75001**

Registrat  
Form

**WHY REGISTER?**

**Warranty Service Protection**  
 No warranty service will be performed on unregistered units

**Firmware Update Notices**  
 Keep informed of new updates for your PCAS and when new products are available

**Save A Stamp!**  
 Register online at <http://register.zaon.aero>

**NAME**   M.I.

First Name

Last Name

**ADDRESS**

Street

Number | Suite ZIP | Postal Code

City State | Prov.

Phone Country

Email

**Would you like to receive product updates and news via e-mail?**

We do not provide your e-mail address to other parties. Yes No

**PRODUCT**   Direct from Zaon

Store or Dealer Name

/  /

Date of Purchase

Serial Number  
 Located on bottom of unit

## Appendix F: Installation and FAA

### Usage Limitations

XRX was designed to be portable and placed on the glare shield for optimum use. Therefore, XRX is not a certified avionics unit. No STC is currently available for use as an installed system. Installation into any other part of the cockpit is not approved by Zoon for the XRX model. The directional antenna is built-in and requires a clear view of the surrounding traffic which can only be achieved by placement in this location. However, installable systems and/or installation upgrades to this model may be available. Contact a Zoon representative for more information.

### FAA Certification

XRX is a Class 1 EFB device and does not require FAA, AIR or AEG evaluation or certification for normal, portable use. No FAA approval is needed if used in a Sport or Experimental aircraft class. However, if you plan to install XRX into a certificated aircraft, you may need the installation to be approved by your installer as a minor alteration or a major alteration at his/her discretion, and/or your local FAA Flight Standards Field Office (FSDO). If approving the installation of this unit through the local FSDO, a Form 337 Field Approval Application must be completed for your particular aircraft and approved by the FAA to be in full compliance. Zoon is unable to offer assistance with this procedure at this time for Model XRX.

### Audio Schematic

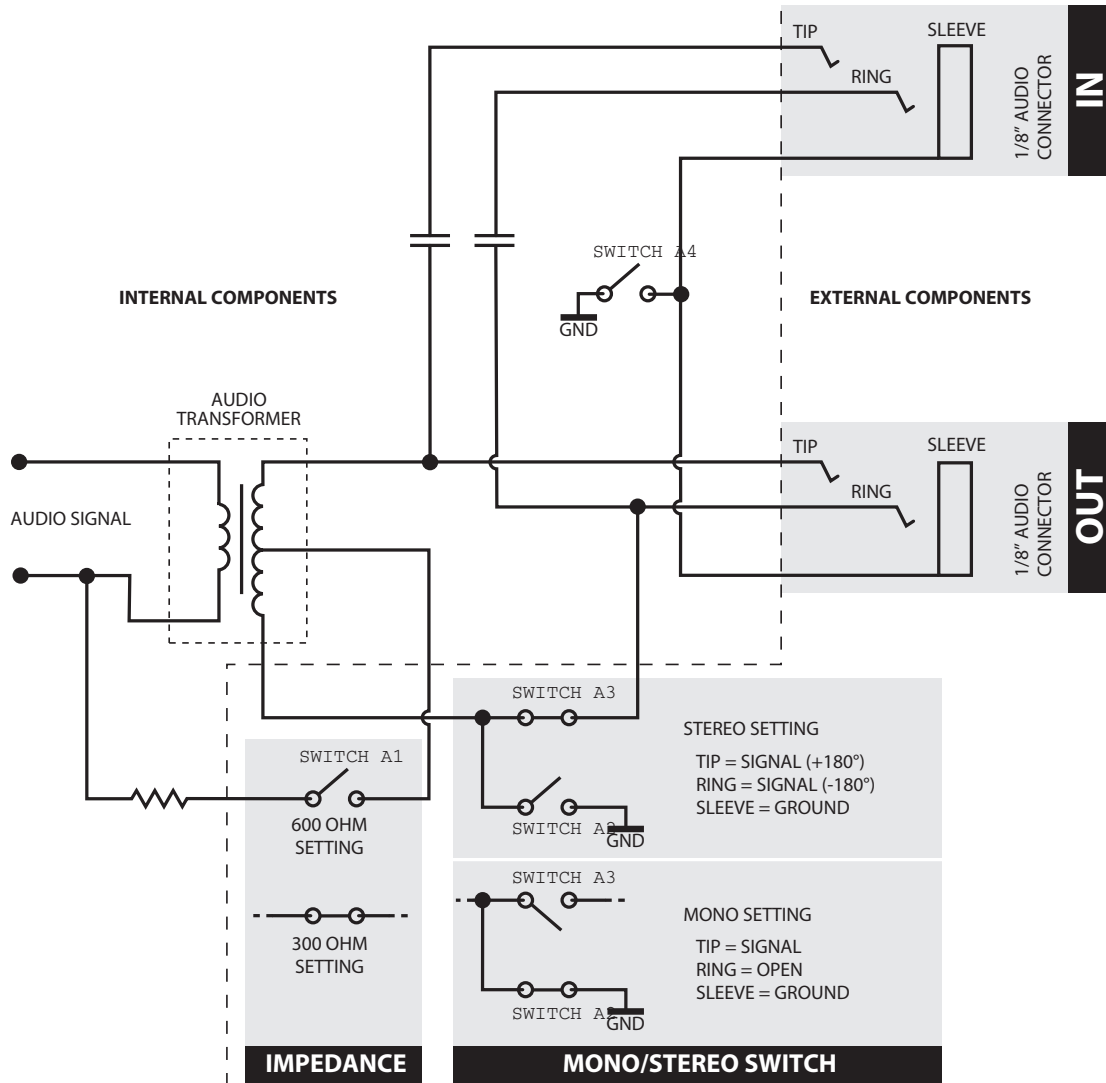

## Appendix G: Regulatory Information

### FCC Regulations

This device complies with Part 15 of the FCC Rules. Operation is subject to the following two conditions: (1) This device may not cause harmful interference, and (2) this device must accept any interference received, including interference that may cause undesired operation.

This equipment has been tested and found to comply with the limits for a Class B digital device, pursuant to Part 15 of the FCC Rules. These limits are designed to provide reasonable protection against harmful interference when the equipment is operated in a commercial environment. This equipment generates, uses, and can radiate radio frequency energy and, if not installed in accordance with the instruction manual, may cause harmful interference to radio communications.

### Canadian Regulations

This Class B digital apparatus meets all requirements of the Canadian Interference-Causing Equipment Regulations. (Cet appareil numérique de la classe B respecte toutes les exigences du Règlement sur le matériel brouilleur du Canada.)

### European Economic Community Declaration of Conformity

According to ISO/IEC Guide 22 and EN 45014

Manufacturer's Name: Zaon Flight Systems, Inc.

Manufacturer's Address: 15946 Midway Road, Addison, TX 75001 USA



declares that the product

Product Name: PCAS  
 Model Number: XRX  
 Product Options: None

conforms to the following product Specifications:

The EMC Directive 89/336/EEC\*  
 Emissions: Harmonized CISPR Standard EN 55022  
 Meets or exceeds RTCA DO-138 Category B  
 Immunity: Harmonized Basic Standard EN 50082-1

The product herewith complies with the requirements of the EMC Directive 89/336/EEC of the European Community and carries the CE marking accordingly.

\* The product was tested in a typical usage configuration.

Zaon Flight Systems, Inc.  
 Office of Quality Manager  
 Addison, TX  
 November 2005

European Contact: Sky Fox GmbH, Pfalzburger Str. 43-44, Berlin, Germany (Fax 49 30 864 746 99)



This page left blank intentionally

# Index

## A

Accessories .....	7, 10, 50, 57, 59
Accuracy .....	15
Admin mode .....	36, 43
Menus .....	44
Aircraft Type .....	38
airframe shadowing .....	33
Alerts .....	16
altimeter .....	18, 48
Calibration .....	47
pressurized mode .....	9
reasons for local altimeter .....	19-23
Altitude .....	15
Menu .....	40
altitude, local .....	14, 46, 50, 54
Antenna .....	8, 17
ATC .....	19, 31, 52, 53, 54
and TIS .....	49
Audio .....	6, 50
Adapters .....	7
Configuring .....	7
Direct Wiring .....	8
Grounding .....	8
Headset-Direct™ Configuration .....	6
Impedance .....	8
Mono/Stereo .....	8
Schematic .....	65
Testing .....	7, 46
tone generator .....	7, 16, 36, 49

## B

Backlight, dimming .....	36
Blue Mountain Avionics .....	41

## C

Calibration .....	9
Altimeter .....	47
Compass .....	45
Initial .....	9
Carry Case .....	10
compass .....	9, 14, 15, 18, 49
Calibration .....	45

    turning errors .....

34	
Cones of Confusion .....	33
configuration switches .....	41, 58
Configuring the Audio .....	7

## D

Detection Window .....	11, 32, 39-40
direction (bearing) .....	11, 12, 15, 17
ambiguity .....	32
Indicators .....	13
display flash .....	16

## E

Examples .....	26
A Single Aircraft .....	27
Direction .....	13
prioritizing .....	15, 28

## F

Firmware .....	60
----------------	----

## G

Garmin .....	41
gliders .....	48
Grand Rapids Technologies .....	41
ground isolation .....	7

## H

heading, local .....	14
----------------------	----

## I

image altitude .....	19
impedance .....	7
Installation .....	64
integration .....	41

## L

Limitations .....	31, 32
automobile, use in .....	5
Local .....	14
altitude .....	14
heading .....	14

<b>M</b>	
Menus .....	37
aircraft type .....	38
Altitude .....	40
Com .....	41, 50
Range .....	39
Screen Options .....	42
mono/stereo selectivity .....	7
Multipath .....	22
Mute .....	36, 37
<b>N</b>	
NOALT indication .....	9
<b>P</b>	
PCAS .....	1, 11
Placement .....	4
glareshield .....	4
Power .....	5
External battery packs .....	50
Pressurized Aircraft .....	9
Prioritizing .....	15, 51
<b>R</b>	
RADAR .....	20, 24, 48, 53
Coverage (installations) .....	31
flying below RADAR coverage .....	21
shadow .....	20
range .....	11, 12, 15, 17, 25, 49, 52, 53, 54
Menu .....	39
Reaction Time .....	35
Relative Information .....	17
Built-in Compass for .....	18
Resolution .....	15
RS-232 .....	41, 50, 58
Menu .....	41
<b>S</b>	
Specifications .....	56
squawk code .....	19, 24, 46, 50
startup sequence .....	60
<b>T</b>	
TCAS .....	1, 11, 24, 31, 48
temperature .....	46, 50
Testing the Audio Output .....	7
TIS .....	49
traffic alerts .....	16, 49
Thresholds .....	16
Traffic Screen .....	12
45° correction .....	43, 51
Menu .....	42
Screen A .....	12, 42
Screen B .....	12, 42
transponder .....	18, 48
antenna .....	53
Nearby Transponder Confusion .....	22, 53
Troubleshooting .....	52
<b>U</b>	
Unpacking .....	4
<b>V</b>	
Vertical Trend .....	13
<b>W</b>	
Warranty .....	62

**Table Index**

Table A: Audio-related configuration switch settings .....	8
Table B: Direction Indicators .....	13
Table C: Range and Altitude Resolution .....	15
Table D: Advisory and Alert Thresholds .....	16
Table E: Recognition & Reaction Time .....	35
Table F: Time to Closest Approach Point (CAP) .....	35
Table G: Configuration Switch Definitions .....	58

## My Information

### Serial Number

5-digit number found on label on bottom of unit

\_\_\_\_ \_

### Purchase Date

Month

Day

Year

### Dealer

\_\_\_\_\_  
 Direct through Zaon

### Firmware Revision History

Date	Version
Shipped	_____
_____	_____
_____	_____
_____	_____
_____	_____
_____	_____

To keep up-to-date:

[www.zaon.aero](http://www.zaon.aero)

For technical questions:

[support@zaon.aero](mailto:support@zaon.aero)

### Notes

\_\_\_\_\_

\_\_\_\_\_

\_\_\_\_\_

\_\_\_\_\_

\_\_\_\_\_

\_\_\_\_\_

\_\_\_\_\_

\_\_\_\_\_

\_\_\_\_\_

\_\_\_\_\_

\_\_\_\_\_